

Philipps



Universität
Marburg

Fachbereich 12: Mathematik und Informatik

About GKM- and non-abelian Hamiltonian actions

Dissertation

zur Erlangung des Doktorgrades
der Naturwissenschaften (Dr. rer. nat.)

eingereicht von

Nikolas Wardenski

unter Betreuung von
Prof. Dr. Oliver Goertsches

Abstract

This thesis revolves around two different, but not entirely unrelated topics. The first is the realization problem in GKM theory, the second is the topic of multiplicity free manifolds.

Regarding the realization problem, we first show that a large class of GKM graphs is in fact a restriction of a torus graph. This involves realizable GKM_4 -graphs, so in particular realizable graphs in general position with valence at least 5. The corresponding GKM manifolds were studied first by Ayzenberg and later also Masuda in [A18] and [AM19]. Then, we give a sufficient criterion for when a T^2 -manifold of dimension 6 is equivariantly formal, and use this, building on [GKZ22], to show that every orientable, 3-valent GKM graph is realizable as an equivariantly formal T^2 -manifold.

After that, we switch to the realization of certain GKM fiber bundles, as first studied in [GKZ20]. More precisely, we characterize which GKM fiber bundles $\Gamma \rightarrow \Gamma' \rightarrow B$ are realizable. Here B is the GKM graph of a quasitoric manifold of dimension 4, and Γ is the GKM graph of a generalized flag manifold of the form G/T , where $T \subset G$ is a maximal torus.

At the end, we also construct many non-trivial examples of such GKM fiber bundles.

The last chapter is essentially the article [GSW22], where we study multiplicity free $U(2)$ -manifolds. Multiplicity free manifolds naturally generalize the class of toric manifolds as studied in [Del88] to non-abelian Lie groups. Friedrich Knop [Kno11] was able to classify those in terms of their principal isotropy type and their invariant momentum polytope, building directly on work of Losev [Los09].

We restrict ourselves to the group $U(2)$ and explicitly give the equivariant diffeomorphism types as well as the symplectic form of certain multiplicity free $U(2)$ -manifolds, including those whose momentum image is a triangle.

We also give an easy-to-check characterization of when a multiplicity free $U(2)$ -manifold admits a compatible $U(2)$ -invariant Kähler structure. This turns out to be the case if and only if the corresponding action of $T^2 \subset U(2)$ admits an invariant Kähler structure.

Zusammenfassung

In dieser Dissertation geht es um zwei verschiedene, aber nicht gänzlich unzusammenhängende Themengebiete. Ersteres ist das Realisierungsproblem in GKM-Theorie, zweiteres ist das der (Hamilton'schen) multiplizitätsfreien Mannigfaltigkeiten.

Bezogen auf das Realisierungsproblem zeigen wir zunächst, dass eine große Klasse von GKM-Graphen eine Einschränkung von Torus-Graphen ist. Diese Klasse beinhaltet realisierbare GKM₄-Graphen, also insbesondere realisierbare Graphen in 'general position' mit einer Valenz von mindestens 5. Die dazugehörigen GKM-Mannigfaltigkeiten wurden zuerst von Ayzenberg und dann später noch von Masuda in [A18] und [AM19] betrachtet. Danach wird ein hinreichendes Kriterium für die äquivariante Formalität einer sechsdimensionalen T^2 -Mannigfaltigkeit bewiesen, das dann zusammen mit Ergebnissen aus [GKZ22] dafür benutzt wird, um jeden orientierbaren 3-valenten GKM-Graphen zu realisieren.

Anschließend geht es um die Realisierung gewisser GKM-Faserbündel, was eine Verallgemeinerung von [GKZ20] darstellt. Genauer geben wir eine Charakterisierung dafür an, welche GKM-Faserbündel $\Gamma \rightarrow \Gamma' \rightarrow B$ realisierbar sind. Mit B ist hierbei der GKM-Graph einer vierdimensionalen quasitorischen Mannigfaltigkeit gemeint und Γ ist der GKM-Graph einer verallgemeinerten Fahnenmannigfaltigkeit der Form G/T , wobei $T \subset G$ ein maximaler Torus ist.

Am Ende konstruieren wir auch viele nichttriviale Beispiele solcher GKM-Faserbündel.

Das letzte Kapitel ist essentiell identisch zum Artikel [GSW22], wo wir uns mit multiplizitätsfreien $U(2)$ -Mannigfaltigkeiten beschäftigen. Solche stellen eine natürliche Verallgemeinerung torischer Mannigfaltigkeiten, die in [Del88] klassifiziert wurden, auf nicht-abelsche Liegruppen dar. Friedrich Knop [Kno11] nutzte die vorangegangene Arbeit von Losev [Los09] und konnte diese anhand ihres Hauptisotropietyps und ihres invarianten Impulsbildes klassifizieren.

Wir beschränken uns hier auf die Gruppe $U(2)$ und geben explizit sowohl den äquivarianten Diffeomorphismentyp als auch die symplektische Form gewisser multiplizitätsfreien $U(2)$ -Mannigfaltigkeiten an. Darunter befinden sich solche, deren Impulsbild ein Dreieck ist.

Darauf aufbauend formulieren und beweisen wir ein leicht zu überprüfendes Kriterium dafür, wann eine multiplizitätsfreie $U(2)$ -Mannigfaltigkeit eine kompatible Kählerstruktur, die invariant unter der $U(2)$ -Wirkung ist, zulässt. Es stellt sich heraus, dass dies genau dann der Fall ist, wenn die dazugehörige Wirkung von $T^2 \subset U(2)$ eine solche zulässt.

Acknowledgements

My sincerest gratitude belongs to my first advisor Oliver Goertsches for introducing me to the mathematics i am interested in, and for having the patience to work with me through the years. Thank you not only for all the mathematics you explained to me, but obviously also for teaching me the do's and dont's in a (mathematical) text!

Next, i would like to thank Silvia Sabatini for two reasons. The first one is being the second advisor for this thesis despite the extent of your current schedule and obligations. The second one is giving me the opportunity to participate and speak at the workshop in Cologne. The knowledge and connections i gathered there are invaluable and ultimately reach back to you, many thanks for this!

Then, i want to explicitly mention the utmost importance of Ilka Agricola for my development. You taught me a big chunk of the foundations of mathematics in my early years of studies, and eventually allowed me to be part of this research group so early on. Plus, i really enjoyed all the (pizza) parties at your place :)

On a more personal level, i would like to thank all the people in the research group for making the time at work more enjoyable, especially Giovanni Russo, Max Schmitt, Henrik Naujoks, Jonas Henkel and Benjamin Bäcker. Ah, and Taki i guess.

Yet another debt of gratitude i owe to the German Academic Scholarship Foundation for giving me the financial freedom necessary to work on my thesis, and for allowing me to be part of the network that enabled me to meet many new interesting people in various events!

At last, i want to mention my family. My mother Sabrina and my father Peter as well as his wife Steffie that gave me the necessary support (and clothes) throughout my whole phase of education. My grandparents Margret and Toni for enjoyable mini-vacations with lovely food and even lovelier stories. And my three sisters Hannah, Emilie and Pauline that put me through hell multiple times, allowing me to toughen up and endure other hard moments in my life more easily.

Contents

| | |
|----------------------------------------------------------------------------------------|-----------|
| Introduction | 1 |
| 1 Preliminaries | 3 |
| 1.1 Serre spectral sequence | 3 |
| 1.2 GKM actions | 5 |
| 1.2.1 Some notation | 5 |
| 1.2.2 GKM graphs and their orientations | 6 |
| 1.2.3 j -independence and the formality package | 10 |
| 1.2.4 Torus manifolds and equivariant formality | 13 |
| 1.2.5 GKM fibrations, GKM fiber bundles and generalized flag manifolds | 13 |
| 1.3 Multiplicity free manifolds | 15 |
| 1.4 Homogeneous fiber bundles | 21 |
| 2 Label extension and realization of 3-valent GKM graphs | 25 |
| 2.1 Label extension of certain GKM graphs | 26 |
| 2.2 A sufficient criterion for equivariant formality and 3-valent GKM graphs | 28 |
| 3 Realization of GKM fibrations | 32 |
| 3.1 Graph automorphisms | 32 |
| 3.2 Examples of GKM fiber bundles | 35 |
| 3.3 The construction | 38 |
| 4 Multiplicity free $U(2)$-manifolds and triangles | 43 |
| 4.1 Multiplicity free $U(2)$ -actions with trivial principal isotropy group | 44 |
| 4.2 Triangles | 55 |
| 4.3 Diffeomorphism types | 67 |
| Bibliography | 70 |

Introduction

It is a well-known theorem by Emmy Noether that every symmetry of a physical system leads to a preserved quantity of this system. For example, the time-invariance of Newtonian mechanics leads to the well-known invariance of energy, and the rotational symmetry of the gravitational field of a point mass (or a homogeneous planet) leads to the preservation of angular momentum. In both cases, this concept of symmetry allows us to gain valuable information about a physical system without solving the corresponding differential equations in full generality, and thus proved itself to be of exaggarating importance in physics.

As per usual, mathematicians eventually started to study this real-world motivated concept systematically, starting with Sophus Lie and Felix Klein in the 1870s. While for the first decades, the development of the theory of continuous transformation groups as well as their actions on vector spaces were the focus of research, the study of smooth actions of Lie groups on smooth manifolds, both from a geometric and a topological point of view, eventually became more and more important.

In the topological aspect, the concept of equivariant cohomology plays a huge role in the development of equivariant differential topology, especially with respect to actions of tori. For example, it was shown in [GKM98], using the Chang-Skjelbred lemma [CS74], that the equivariant cohomology, and thus the ordinary cohomology, of a smooth manifold with vanishing odd-degree cohomology endowed with a torus action whose equivariant one-skeleton is a finite union of 2-spheres is determined by the equivariant one-skeleton itself (which is naturally encoded by a labeled graph). Conversely, one can ask whether to a given labeled graph Γ there are torus actions on manifolds as above whose equivariant one-skeleton gives rise to Γ . Partial results in dimension 6 were given in [GKZ22], and these results will be extended in this thesis.

In the geometric aspect, especially the notion of a Hamiltonian action comes to mind, that is, an action of a Lie group on a simply-connected manifold under which a symplectic form is preserved. Although the theory becomes extraordinarily beautiful when restricting to torus actions (see for example the convexity theorem by Atiyah, Guillemin and Sternberg [Ati82], [GS82] or the classification of toric manifolds by Delzant [Del88]), there are also many nice results for general compact, connected Lie groups. For instance, Knop [Kno11] was able to build on previous work of Losev [Los09] and classified multiplicity free Hamiltonian

manifolds, thus generalizing the work of Delzant [Del88], [Del90] in this matter. Here, we will study Hamiltonian actions of $U(2)$ on sixdimensional manifolds more explicitly, that is, we describe the $U(2)$ -equivariant diffeomorphism type as well as the symplectic form on these explicitly (Knop's result just gives multiplicity free manifolds rather abstractly based on their invariant momentum polytope). This enables us to also answer the question when a given multiplicity free $U(2)$ -manifold in dimension 6 admits a compatible invariant Kähler metric.

Structure

In Chapter 1, we will outline basic properties of Hamiltonian group actions as well as basics of equivariantly formal GKM-actions, assuming that the reader is familiar with basic algebraic topology and the notion of a Lie group action on a smooth manifold.

In Chapter 2 we will describe a criterion for when the label of a GKM graph can be extended to a 'full' labeling, or equivalently, for when a GKM graph is the restriction of a torus graph. After that, using parts of [GKZ22], we show that every 3-valent GKM graph with (signed or unsigned) \mathbb{Z}^2 -labeling is realizable as an equivariantly formal (over \mathbb{Z}) T^2 -manifold.

In Chapter 3, we will build upon [GKZ20] and give a characterization for realizable GKM fiber bundles $\Gamma \rightarrow \Gamma' \rightarrow B$, where Γ is the GKM graph of a generalized flag manifold G/T and B is the GKM graph of a fourdimensional, equivariantly formal torus manifold.

In Chapter 4, we construct certain multiplicity free $U(2)$ -manifolds with trivial principal isotropy group explicitly, determine their diffeomorphism type based on their invariant momentum polytope, and give a description which of all multiplicity free $U(2)$ -manifolds with trivial principal isotropy group admit a compatible invariant Kähler metric.

While Chapter 2 was done by the author himself, Chapter 3 is joint work with Oliver Goertsches, Panagiotis Konstantis and Leopold Zoller, whereas Chapter 4 together with the part of Chapter 1 regarding multiplicity free manifolds and homogeneous fiber bundles is joint work with Oliver Goertsches and Bart van Steirteghem.

Chapter 1

Preliminaries

1.1 Serre spectral sequence

Here we fix some notation regarding the Serre spectral sequence for fiber bundles (over \mathbb{Z} or \mathbb{Q}). We should note that we always talk about singular homology with coefficients either in \mathbb{Q} or \mathbb{Z} whenever we talk about 'homology'. As long as not specified, coefficients are allowed to be both \mathbb{Q} or \mathbb{Z} . See e.g. [Hat04] for details.

Let $F \rightarrow M \rightarrow B$ be a fiber bundle over a connected CW-complex B , and assume that the homology of B or F over \mathbb{Z} respectively \mathbb{Q} is finitely generated. The point of the Serre spectral sequence is to compute the homology of the space M from the homology of B and F via a first quadrant spectral sequence, only subject to the small condition that the monodromy representation $\pi_1(B) \rightarrow \text{Aut}(H_*(F))$ is trivial. This is true, for example, when the bundle restricted to the one-skeleton of B is trivial, so in particular for free group actions of a connected Lie group. Usually, one starts from the second page, which has the form

$$E_{p,q}^2 = H_p(M^*, H_q(F)) = H_p(M^*) \otimes H_q(F)$$

(where the last equation always holds over \mathbb{Q} , and also over \mathbb{Z} if the homology of F , for example, is torsion free, which we assume from now on) and the differential $d_{p,q}^2: E_{p,q}^2 \rightarrow E_{p-2,q+1}^2$ (it will not matter for us how this differential looks like). Now, the third page is the homology of the second page, that is,

$$E_{p,q}^3 := \frac{\ker(d_{p,q}^2: E_{p,q}^2 \rightarrow E_{p-2,q+1}^2)}{\text{im}(d_{p+2,q-1}^2: E_{p+2,q-1}^2 \rightarrow E_{p,q}^2)}.$$

The new differential now is of the form $d_{p,q}^3: E_{p,q}^3 \rightarrow E_{p-3,q+2}^3$. Again, we do not have to know how this looks like exactly.

In general, we define $E_{p,q}^{r+1}$ from $E_{p,q}^r$ by

$$E_{p,q}^{r+1} := \frac{\ker(d_{p,q}^r: E_{p,q}^r \rightarrow E_{p-r,q+r-1}^r)}{\text{im}(d_{p+r,q-r+1}^r: E_{p+r,q-r+1}^r \rightarrow E_{p,q}^r)}$$

with differential $d_{p,q}^{r+1}: E_{p,q}^{r+1} \rightarrow E_{p-r,q+r-1}^{r+1}$. Note that, for r big enough, $E^r = E^{r+1} = E^{r+2} = \dots$, because we assumed the homologies of B or F to be finitely generated. We then define $E_{p,q}^\infty := E_{p,q}^r$ and say that the spectral sequence (E^r, d^r) converges against E^∞ . The homology of M is encoded in E^∞ . Denote by $(B)_p$ the p -skeleton of B , and by M_p its preimage under $\pi: M \rightarrow B$.

Theorem 1.1.1. *We have*

$$E_{p,q}^\infty = \text{im}(H_{p+q}(M_p) \rightarrow H_{p+q}(M)) / \text{im}(H_{p+q}(M_{p-1}) \rightarrow H_{p+q}(M))$$

and therefore, over \mathbb{Q} , the isomorphism

$$H_k(M) \cong \bigoplus_{p+q=k} E_{p,q}^\infty.$$

Remark 1.1.2. Over \mathbb{Z} , there is no reason to assume that

$$H_k(M) \cong \bigoplus_{p+q=k} E_{p,q}^\infty$$

since short exact sequences of abelian groups do not necessarily split. Instead, in order to calculate $H_k(M)$ for a given k , we get a series of extension problems to solve. That is, assuming we know the image K of $H_k(M_{p-1}) \rightarrow H_k(M)$ (which is $E_{0,k}^\infty$ for $p = 1$), the image H of $H_k(M_p) \rightarrow H_k(M)$ sits in the short exact sequence

$$0 \rightarrow K \rightarrow H \rightarrow E_{p,k-p}^\infty \rightarrow 0.$$

Lemma 1.1.3. *Let $F_1 \rightarrow X \rightarrow B_1$ and $F_2 \rightarrow M \rightarrow B_2$ be bundles as above and consider a bundle map $f: X \rightarrow M$ covering $g: B_1 \rightarrow B_2$. We consider the spectral sequences $E^r(X)$ and $E^r(M)$ belonging to X and M , respectively. Then the following statements hold:*

1. *There is a map $f_*^r: E^r(X) \rightarrow E^r(M)$ which commutes with the differentials, where f_*^{r+1} is induced by f_*^r in the canonical way and f_*^2 is the canonical map $g_* \otimes i_*$, where $i_*: H_*(F_1) \rightarrow H_*(F_2)$ is the well-defined homomorphism in homology induced by f and generic fiber inclusions i_1 and i_2 .*
2. *The map $H_*(X) \rightarrow H_*(M)$ induced by f is compatible with f_*^∞ in the sense that it induces maps between the group extensions from above.*

Now let a connected Lie group G act freely on a CW-complex M . We get a fiber bundle $G \rightarrow M \rightarrow M/G$ which is trivial over $(M/G)_1$. So we can always use the Serre spectral sequence in these situations, even with \mathbb{Z} -coefficients.

It is a crucial fact that, if $G = T^n$ is abelian and acts almost freely (that is, only with discrete isotropies), then the Serre spectral sequence even works in this case (together with all naturality properties), under the mild restriction that one takes \mathbb{Q} -coefficients. We will

outline the reason here, see [Z16, Lemma 2.8] for details. We consider the homotopy fiber F_p of p in $M \rightarrow M_{T^n} \xrightarrow{p} BT^n$, and the following bundle

$$\Omega BT^n \rightarrow F_p \rightarrow M_{T^n}.$$

Together with the natural homotopy equivalence $M \rightarrow F_p$, there can be constructed a homotopy equivalence $h: T^n \rightarrow \Omega BT^n$ such that the diagram

$$\begin{array}{ccccc} T^n & \longrightarrow & M & \longrightarrow & M_{T^n} \\ \downarrow & & \downarrow & \nearrow & \\ \Omega BT^n & \longrightarrow & F_p & & \end{array}$$

commutes. That is, we can say that $T^n \rightarrow M \rightarrow M_{T^n}$ is a 'fibration up to homotopy equivalence'. Now, $H^*(M/T; \mathbb{Q}) \rightarrow H_T^*(M; \mathbb{Q}) = H^*(M_{T^n})$ is an isomorphism, and the monodromy of $\Omega BT^n \rightarrow F_p \rightarrow M_{T^n}$ is trivial, so its Serre spectral sequence computes the (co)homology of M with rational coefficients. The naturality conditions now come from the naturality of the constructed fibration $\Omega BT^n \rightarrow F_p \rightarrow M_{T^n}$.

1.2 GKM actions

1.2.1 Some notation

Let M be a compact, oriented smooth manifold of dimension $2n$ on which a torus T of dimension m acts effectively. We use the standard notations Tx and $T_x \subset T$ for the orbit of T through $x \in M$ and the stabilizer of x in T , respectively. For H an arbitrary subgroup of T , we define $M^{(H)}$ to be all elements $x \in M$ with $T_x = H$ and M^H to be all elements $x \in M$ satisfying $H \subset T_x$. We denote by M_k the equivariant k -skeleton of M , that is,

$$M_k := \{x \in M \mid \dim(Tx) \leq k\} = \{x \in M \mid \dim(T_x) \geq m - k\}.$$

We get a filtration of M by

$$M^T = M_0 \subset M_1 \subset \dots \subset M_{m-1} = M$$

and an induced filtration of the orbit space $M/T = M^*$, where for any T -invariant set $X \subset M$ we set X^* to be the image of the projection $\pi: M \rightarrow M/T$. From now on, we **always** assume that M^T is finite and nonempty.

Definition 1.2.1. The closure F of a connected component of $M_i^* \setminus M_{i-1}^*$ in M^* is called a *face* if it intersects M_0^* non-trivially. We define its rank $\text{rk}(F)$ to be the number i and call $\pi^{-1}(F)$ a *face submanifold*.

We note that the latter definition is justified since $\pi^{-1}(F)$ is indeed a submanifold of M . Also, for any face F , we set

$$F_{-1} := \{x \in F: \dim Tx < \text{rk}(F)\}.$$

1.2.2 GKM graphs and their orientations

For a graph Γ , we denote by $E(\Gamma)$ the set of all edges and by $V(\Gamma)$ the set of all vertices. We can give each edge e two possible orientations, each determining an initial vertex $i(e)$ and a terminal vertex $t(e)$, respectively. On an oriented edge e , we denote by \bar{e} the same unoriented edge with the other orientation. Thus $i(e) = t(\bar{e})$ and $t(e) = i(\bar{e})$. We let $\tilde{E}(\Gamma)$ be the set of all oriented edges, and let E_v and \tilde{E}_v be the corresponding edges on any $v \in V(\Gamma)$. An abstract unsigned GKM graph (Γ, α) consists of an n -valent graph Γ (multiple edges may appear between two vertices) and a *labeling* $\alpha: E(\Gamma) \rightarrow \mathbb{Z}^k / \pm 1$ such that for all $v \in V$ and any two e_1, e_2 at v , $\alpha(e_1)$ and $\alpha(e_2)$ are linearly independent, and such that there is a compatible connection ∇ , which we define now.

Definition 1.2.2. A compatible connection ∇ on (Γ, α) is a bijection $\nabla_e: \tilde{E}_{i(e)} \rightarrow \tilde{E}_{t(e)}$ (for each oriented edge e) such that

1. $\nabla_e e = \bar{e}$.
2. $\nabla_{\bar{e}} = (\nabla_e)^{-1}$.
3. for all $f \in \tilde{E}_{i(e)}$ we have $\alpha(\nabla_e f) \pm \alpha(f) = c\alpha(e)$ for some $c \in \mathbb{Z}$.

Analogously, we call (Γ, α) an abstract **signed** GKM graph when α takes values in \mathbb{Z}^k , $\alpha(e) = -\alpha(\bar{e})$, and there is a compatible connection such that the third condition above is replaced with $\alpha(\nabla_e f) - \alpha(f) = c\alpha(e)$.

There is a rather obvious notion of isomorphism of GKM graphs.

Definition 1.2.3. Two (signed) GKM graphs (Γ, α) and (Γ', α') are isomorphic if there exists an isomorphism $\Psi: \Gamma \rightarrow \Gamma'$ of unlabeled graphs, as well as an automorphism $\varphi: \mathfrak{t}^* \rightarrow \mathfrak{t}^*$ such that $\varphi(\alpha(e)) = \alpha'(\Psi(e))$.

There is a relationship between T^k -actions on \mathbb{C}^n and the values of α on E_v . Namely, for every edge $e \in E_v$, $\alpha(e)$ corresponds to a homomorphism $\chi_e: T^k \rightarrow S^1$, which is well-defined up to complex conjugation on S^1 . In particular, the representation χ_v of T^k on $\mathbb{C} \cong \mathbb{R}^2$ defined by χ_e is well defined up to (real) isomorphism, and thus we get a representation of T^k on \mathbb{C}^n (up to real isomorphism) by

$$t \cdot (z_1, \dots, z_n) = (\chi_{e_1}(t)z_1, \dots, \chi_{e_n}(t)z_n).$$

We denote this representation by $\mathbb{C}^n(v)$. Note that the equivariant one skeleton $(\mathbb{C}^n(v))_1$ of $\mathbb{C}^n(v)$ is precisely the union of the single \mathbb{C} -summands, because we assumed that any two labels are linearly independent. Of course, every T^k -representation on \mathbb{C}^n such that \mathbb{C}_1^n is the union of single \mathbb{C} -summands is of the above form, so determines a 'labeling'. More generally, we have the following lemma.

Lemma 1.2.4. *Let M be a possibly open manifold acted on by $T = T^k$ smoothly with the following properties:*

- The set M^T is finite and not empty.
- The equivariant one skeleton M_1 is given by a union of T -invariant 2-spheres.

Then the set $\Gamma = M_1/T$ has a natural graph structure (vertices correspond to fixpoints, edges correspond to T -invariant 2-spheres), and there is a labeling α determined by the isotropy representation at each vertex. Moreover, the tuple (Γ, α) is a GKM graph.

From now on, we will omit the labeling α and will only write about 'the GKM graph Γ '.

Remark 1.2.5. We will associate a T^k -manifold M'_1 (this can be seen as an 'equivariant tubular neighborhood' of the equivariant one-skeleton) with boundary $X_1(\Gamma)$ to a GKM graph Γ . The construction will depend on certain choices, for example the connection on Γ . We will deal with this later.

For a fixed element p in $V(\Gamma)$, we denote by \mathbb{C}_p^n a representation of T^k on \mathbb{C}^n according to the labels of the edges emerging at p and by $S(p), D(p) \subset \mathbb{C}_p^n$ the unit sphere resp. the unit disc (this corresponds to choosing signs for the labels). Let T' be some tree of the graph. Whenever two vertices p_1 and p_2 are connected by an edge in T' , then we consider the equivariant connected sum of $S(p_1)$ and $S(p_2)$ along their shared invariant subcircle, which means that we take out a neighborhood of this S^1 in both $S(p_1)$ and $S(p_2)$ and glue the spaces along the boundaries $S^1 \times S^{2n-3}$ with a T^k -equivariant diffeomorphism that restricts to a linear isomorphism $h_{(p_1, p_2)}$ on $\{e\} \times S^{2n-3}$ which sends $S^1 \subset S^{2n-3}$ corresponding to an edge e at p_1 to $S^1 \subset S^{2n-3}$ corresponding to the edge $\nabla_{(p_1, p_2)}e$ (this is well-defined due to the compatibility condition of connection and labeling of the graph). This will be the boundary of the space

$$M' = ((D(p_1) \setminus S^1) \amalg (D(p_2) \setminus S^1)) / \sim,$$

where we identify those two in an open neighborhood of the S^1 's we take out (this open neighborhood minus S^1 is equivariantly diffeomorphic to $S^1 \times D^{2n-2} \times (0, 1]$, so we can identify those neighborhoods in the same way as for the $S(p_i)$ before). Also, there is a natural map r_1 from M' to the T -invariant sphere inside it, which is an equivariant deformation retract. This comes from the natural deformation retracts from the $D(p_i)$ to 0. Indeed, we can deform these on $D(p_i) \setminus S^1$ only in a neighborhood of S^1 as indicated in fig. 1.1 and now it is clear that this extends to the desired map r_1 on M' .

Doing this for all points in T' we obtain a simply-connected T^k -manifold $M'_1(T')$ with boundary $X_1(T')$ and the map $r_1(T')$ to its equivariant one-skeleton. Now we take an edge $e \in \Gamma \setminus T'$ with vertices v_1 and v_2 , and perform the equivariant connected sum, again. Doing this for all edges in $\Gamma \setminus T'$ gives us a (not necessary orientable!) T^k -manifold M'_1 (with the map r_1 to its one-skeleton, and with boundary X_1) whose fundamental group is isomorphic to that of Γ . We also have $H_2(X_1) \cong H_2(M_1)$ realized by r_1 , which can be seen inductively, using the iterative construction of M_1 respectively X_1 and the Mayer Vietoris sequence. Indeed, when we denote by $X_1(k)$ the manifold constructed corresponding to a subtree $T_k \subset T'$ with k edges and we assume that both $X_1(k)$ and $M_1(k)$ have second homology \mathbb{Z}^k , then the second homology group of $X_1(k+1)$ (and similar for $M_1(k+1)$) sits in

$$\dots \rightarrow H_2(X_1(k) \setminus S^1) \oplus H_2(S^{2n-1} \setminus S^1) \rightarrow H_2(X_1(k+1)) \rightarrow H_1(S^1 \times S^{2n-3}) \rightarrow \dots$$

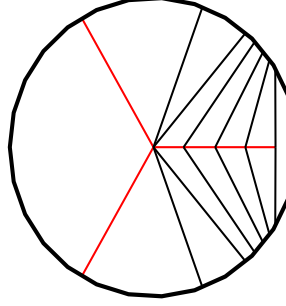

Figure 1.1: The deformation for $n = 3$. The red lines represent the one-skeleton, and the black lines the map.

The assertion follows because $H_2(X_1(k) \setminus S^1) = H_2(X_1(k))$, $H_2(S^{2n-1} \setminus S^1) = 0$ and

$$H_1(S^1 \times S^{2n-3}) \rightarrow H_1(X_1(k) \setminus S^1) \oplus H_1(S^{2n-1} \setminus S^1)$$

is the 0-map. Similarly, we can argue for each step after $X_1(T')$ is already constructed (that is, when we start gluing $X_1(T')$ to itself).

Note that the statement about the second homology groups does not depend on the choices of the T^k -representation on \mathbb{C}^n made.

We made some choices in the construction. In order to argue that they are not restrictive, we need an elementary lemma.

Lemma 1.2.6. *Let $A \in O(2n)$ act linearly on $\mathbb{R}^{2n} = (\mathbb{R}^2)^n = \mathbb{C}^n$ such that it commutes with an S^1 -representation that only fixes 0. Then A is contained in the standard $U(n) \subset SO(2n)$.*

Proof. Write $A = BS$ for $B \in SO(2n)$ and S for the reflection $\text{diag}(-1, 1, \dots, 1)$. Then the S^1 -action commutes with A if and only if the with B conjugated S^1 -action commutes with S . An element C in $SO(2n)$ commutes with S if and only if $C_{\geq 2,1} = -C_{\geq 2,1}$ and $C_{1,\geq 2} = -C_{1,\geq 2}$, so if and only if $C \in (O(1) \times O(2n-1)) \cap SO(2n)$. Thus, the conjugated S^1 -action would have to be trivial on the first two summands $\mathbb{R} \oplus \mathbb{R} \subset \mathbb{R}^{2n}$, which contradicts the assumption that the initial S^1 -action only fixes 0.

It follows that $A \in SO(2n)$, and now it is a straightforward computation that A has to be in the standard $U(n) \subset SO(2n)$. \square

Now we can slowly go through the choices made in remark 1.2.5.

Remark 1.2.7. In the construction, we specified how the linear isomorphism $h = h_{(p_1, p_2)}$ has to look like, but actually any choice of linear isomorphism g with respect to which the gluing map $S^1 \times S^{2n-3} \rightarrow S^1 \times S^{2n-3}$ becomes T^k -equivariant will be homotopic to linear isomorphisms with the same property (which makes the resulting manifolds equivariantly diffeomorphic). To see this, we view g as a map $\mathbb{C}^{n-1} \rightarrow \mathbb{C}^{n-1}$ and denote by T' the kernel of $\alpha = \alpha((p_1, p_2))$. This is of the form $T \times Z$, where T is a $k-1$ -dimensional torus and Z a cyclic subgroup (non-trivial if and only if α is not primitive). Now T' acts on both copies of

\mathbb{C}^{n-1} and g has to be equivariant with respect to these actions. In particular, g respects the isotropy types of T . The corresponding isotropy submanifolds are necessarily subspaces of \mathbb{C}^{n-1} on which the action of T , after dividing out the kernel, becomes a diagonal S^1 -action. Z also acts on those via rotation, so that the isotropy submanifolds of the T' -action also are subspaces on which the action of T' , after dividing out the kernel, becomes a diagonal S^1 -action. Hence, both any g and h restricted to any such m -dimensional subspace S will be equivariantly homotopic to each other, because $h^{-1} \circ g$ is contained in $U(m)$ by lemma 1.2.6 and centralizes a subcircle $S^1 \subset U(m)$, so that $h^{-1} \circ g$ is homotopic to the identity through elements in $U(m)$ centralizing this S^1 .

Definition 1.2.8. We call the GKM graph Γ *orientable* if there exists a choice of representations \mathbb{C}_p^n , $p \in V(\Gamma)$, and a connection ∇ on Γ such that $X_1(\Gamma)$ as in remark 1.2.5 is orientable.

Remark 1.2.9. This does not actually depend on the choice of connection. To see this, choose a connection together with choices of representations \mathbb{C}_p^n such that X_1 becomes orientable. This gives certain orientations of the $S(p_i)$, which we use from now on.

We need to analyze h on every S from above. Note that the choices of representations \mathbb{C}_p^n give rise to different signs of the free S^1 -action on S , depending on whether we view it as contained in $S(p_1)$ or $S(p_2)$. Now, if k_1 is the number of negative weights of S in $S(p_1)$ and k_2 is the number of negative weights of S in $S(p_2)$, then h preserves orientation if and only if $k_1 - k_2$ is even, and this is the same for a new connection chosen. We deduce that the new induced map from $S^1 \times S^{2n-3}$ in $S(p_1)$ to $S^1 \times S^{2n-3}$ in $S(p_2)$ preserves orientation if and only if it did with the old connection, and this shows the claim.

Remark 1.2.10. Note that this was a construction based on an abstract GKM graph. However, given a GKM manifold M whose graph Γ is orientable, it is straightforward to see that, with the choices of signs coming from the orientability, $M'_1(\Gamma)$ can be embedded equivariantly into M . Indeed, M'_0 can clearly be embedded equivariantly (with those choices of signs), and we may modify this embedding in such a way that, whenever (p_1, p_2) is an edge, $D(p_1)$ and $D(p_2)$ touch precisely in neighborhoods $\mathcal{N}_1(S^1)$ respectively $\mathcal{N}_2(S^1)$ of the shared subcircle in their boundaries and the induced map

$$S^1 \times D^{2n-2} = \mathcal{N}_1(S^1) \rightarrow \mathcal{N}_2(S^1) = S^1 \times D^{2n-2}$$

is an equivariant fiberwise linear isomorphism. The image of these $D(p_i)$ under this modification is not necessarily a smooth manifold, of course, but we can assure this by slightly shrinking it around the intersections of the $D(p_i)$, and now it is equivariantly diffeomorphic to $M'_1(\Gamma)$.

Remark 1.2.11. There is a natural singular foliation \mathcal{F}_1 , whose leaves are tori of different dimension, on M'_1 . This is given on M'_0 by the orbits of the natural T^n -action on D^{2n} , and this is clearly preserved under the gluing maps used in remark 1.2.5 (although the T^n -action might not be). We will denote by $Y_1 \subset X_1$ (not M'_1 !) the leaves of maximal dimension n . This has the natural structure of a T^n -bundle over a space B_1 which is homotopy equivalent

to Γ , because, via the construction in remark 1.2.5, B_1 is obtained by gluing disks (namely the orbit spaces of the free T^n -orbits of the natural action on S^{2n-1}) onto each other along smaller disks.

Remark 1.2.12. There is also the definition of an oriented graph as in [BP15][Definition 7.9.16]. It is unknown to the author how these definitions are connected.

Definition 1.2.13. The GKM graph Γ is called j -independent, $j \geq 2$, if for any vertex any j labels are linearly independent over \mathbb{Q} .

If $j = k = n - 1$, then we say that the graph is in *general position*.

If $j = k = n$, then we speak of a *torus graph*.

Remark 1.2.14. There are two basic properties of orientability of graphs that we want to mention now.

1. A subgraph Γ' of an orientable torus graph Γ is orientable. Indeed, the manifold $X_1(\Gamma')$ is a connected component of $X_1(\Gamma)^H$ for a closed subgroup $H \subset T^n$, and the normal bundle of $X_1(\Gamma)^H$ is a sum of line bundles, hence orientable.
2. If the fundamental group of a 3-independent graph is generated by connection paths, then it is orientable. The reason is that the equivariant two-skeleton $(X_1)_2$ of X_1 generates $\pi_1(X_1)$, that every connected component of $(X_1)_2$ is equivariantly diffeomorphic to $S^1 \times T^2$ with an action of T^k on T^2 induced by an epimorphism and that the normal bundle of such an $S^1 \times T^2$ is orientable. The last statement is true for 4-independent graphs, because then the normal bundle splits into line bundles. But this is not necessarily true anymore if the graph is 3-independent. In this case, however, there is a linear T^{k-2} -action on the fiber \mathbb{R}^{2n-4} of the normal bundle that only fixes 0 and commutes with the element $A \in O(2n-4)$ that defines the normal bundle of $S^1 = (S^1 \times T^2)/T^2$ in X_1/T^2 . This implies that A is in $U(n-2)$ by lemma 1.2.6.

1.2.3 j -independence and the formality package

From now on, the coefficient ring R for all (co)homology is taken to be either \mathbb{Q} or \mathbb{Z} . Again, we assume T acts smoothly on $M = M^{2n}$ with M^T finite and not empty.

Definition 1.2.15. The action of T is called j -independent, $j \geq 2$, if for any $x \in M^T$ any j weights of the tangent representation of T on $T_x M$ are linearly independent over \mathbb{Q} .

If $j = n - 1$ and $T = (S^1)^j = T^j$, then we say that the action is in *general position*.

If $j = n$ (that is, the torus has maximal dimension), then we speak of a *torus manifold*.

Now we define what an action of GKM_j -type is. This is closely related, but not identical to the action being j -independent.

Definition 1.2.16. A j -independent action is said to be of GKM_j -type or GKM_j if the odd cohomology of M vanishes. For $j = 2$, we just omit the index and speak of a GKM action.

Remark 1.2.17. At first glance, it seems weird to ask for topological properties of the manifold acted on. However, there is a well-known result that, when the set of fixpoints is isolated, this topological restriction is equivalent to the action being equivariantly formal (with respect to the coefficient ring R chosen). That is, denoting by $ET \rightarrow BT$ the classifying bundle of T , the equivariant cohomology

$$H_T^*(M) := H^*(M \times_T ET)$$

is a free $H^*(BT)$ -module, where the module structure comes from the homomorphism $H^*(BT) \rightarrow H^*(M \times_T ET)$ induced by the projection $M \times_T ET \rightarrow BT$. More precisely, we have the isomorphism of $H^*(BT)$ -modules

$$H_T^*(M) \cong H^*(BT) \otimes H^*(M),$$

since the Serre spectral sequence associated to $M \rightarrow M \times_T ET \rightarrow BT$ collapses at the second page due to degree reasons ($H^*(BT)$ is the polynomial ring in $\dim(T)$ generators of even degree). In particular, the restriction map $H_T^*(M) \rightarrow H^*(M)$ is surjective and its kernel is $H^{\geq 1}(BT) \otimes H^*(M)$.

There is a natural way to associate a ring to a GKM graph Γ . In order to do this, we set T to be a k -dimensional torus and note that, abstractly, the group of homomorphisms from T to S^1 is isomorphic to $H^2(BT; \mathbb{Z})$, because both are isomorphic to \mathbb{Z}^k . However, there is even a natural isomorphism, coming from a fact that every homomorphism $T \rightarrow S^1$ gives a map $BT \rightarrow BS^1$ and thus, after fixing some generator of $H^2(BS^1) = \mathbb{Z}$, a unique element in $H^2(BT)$. So, if Γ is signed, we can uniquely identify any weight with an element in $H^2(BT; \mathbb{Z})$, and when Γ is not signed, this only works up to a sign in $H^2(BT; \mathbb{Z})$.

Definition 1.2.18. Let R be either \mathbb{Q} or \mathbb{Z} . The equivariant cohomology $H_T^*(\Gamma; R)$ of a GKM graph Γ is defined by

$$\left\{ (\omega(v))_v \in \bigoplus_{v \in V(\Gamma)} H^*(BT; R) : \omega(u) - \omega(w) \equiv 0 \pmod{\alpha(e)} \text{ for all edges } e \text{ between } u \text{ and } w \right\},$$

where $\omega(u) - \omega(w) \equiv 0 \pmod{\alpha(e)}$ means that $\omega(u) - \omega(w)$ is contained in $H^*(BT; R) \cdot \alpha(e)$. The cohomology $H^*(\Gamma; R)$ of a GKM graph Γ is defined by

$$H^*(\Gamma; R) = H_T^*(\Gamma; R) / (H^{\geq 1}(BT; R) \cdot H_T^*(\Gamma; R)).$$

As one can already guess from the definition, the equivariant cohomology respectively the cohomology of a GKM manifold is strongly linked to the equivariant cohomology respectively the cohomology of the graph. The next theorem is [GKM98, Theorem 7.2], and is obtained by using the equivariant Mayer Vietoris sequence as well as the Chang-Skjelbred Lemma [CS74, Lemma 2.3].

Theorem 1.2.19. *Let M be a GKM T -manifold over \mathbb{Q} . There is an isomorphism of $H^*(BT; \mathbb{Q})$ -algebras $H_T^*(M; \mathbb{Q}) \rightarrow H_T^*(\Gamma; \mathbb{Q})$, induced by the restriction map $H_T^*(M; \mathbb{Q}) \rightarrow H_T^*(M^T; \mathbb{Q})$. This also induces an isomorphism*

$$H_T^*(M; \mathbb{Q}) / (H^{\geq 1}(BT; \mathbb{Q}) \cdot H_T^*(M; \mathbb{Q})) = H^*(M; \mathbb{Q}) \rightarrow H^*(\Gamma; \mathbb{Q}).$$

This holds for any action of GKM_j -type, $j \geq 2$. There are more specific results for higher j , some of which we will list now.

Lemma 1.2.20 ([MP03, Lemma 2.2]). *If the action is equivariantly formal over R , then, for any subtorus $H \subset T$, any connected component of $M^H \subset M$ contains a fixpoint and its odd cohomology vanishes.*

Theorem 1.2.21 ([AMS22, Proposition 3.11]). *If the action is of GKM_j -type and $R = \mathbb{Q}$, then*

1. *for any face F we have $H^i(F, F_{-1}) = 0$ for $i < \text{rk}(F)$. If, in addition, $\text{rk}(F) < j$, then $H^*(F, F_{-1}) = H^*(D^{\text{rk}(F)}, \partial D^{\text{rk}(F)})$.*
2. *M^* is $j + 1$ -acyclic (that is, $H^i(M^*) = 0$ for $1 \leq i \leq j + 1$).*
3. *M_r^* is $\min(r - 1, j + 1)$ -acyclic.*

If one assumes that all stabilizers are connected, then this also holds for $R = \mathbb{Z}$.

There is a kind of inverse to the last theorem.

Theorem 1.2.22 ([AM19, Theorem 4, Chapter 6]). *Assume that the action of T on M is in general position and satisfies the following properties (here, rational coefficients are taken):*

- *every face submanifold contains a fixpoint;*
- *all stabilizers are connected;*
- *the orbit space is a homology $(n + 1)$ -sphere;*
- *each face of Q_{n-2} is a homology disc;*
- *Q_{n-2} is $(n - 3)$ -acyclic.*

Then the action is equivariantly formal.

The assumption on the orbit space being a homology-sphere is not as restrictive as it seems. We call an action in general position **appropriate**, if, for any closed subgroup $H \subset T$, the closure of $M^{(H)}$ contains a point x' whose stabilizer has a larger dimension than H .

Lemma 1.2.23. [A18, Theorem 2.10] *The orbit space of an appropriate T -manifold in general position is a topological manifold.*

We will treat actions in general position that are in some way locally standard, that is, every slice looks just like a slice from some linear $T = T^{n-1}$ -action on \mathbb{C}^n (these are clearly appropriate). Let $x \in \mathbb{C}^n$ be a point, and consider T_x for such an action. This is a closed subgroup of T , hence a product of a subtorus and finite cyclic groups. Since we assume that the action is effective, T_x acts linearly and effectively on the fiber over x of the normal bundle of the subspace fixed by T_x . This fiber is again some \mathbb{C}^k , where $k - 1 = \dim(T_x)$. It follows that T_x acts effectively on $T^k \subset \mathbb{C}^k$, which implies that there is only one finity cyclic group in T_x .

1.2.4 Torus manifolds and equivariant formality

We say that a torus manifold M is *locally standard* if every point in M admits an invariant neighborhood U such that U is weakly equivariantly diffeomorphic to an open subset $W \subset \mathbb{C}^n$ invariant under the standard action of T on \mathbb{C}^n , that is, there is an automorphism $\psi: T \rightarrow T$ and a diffeomorphism $f: U \rightarrow W$ such that $f(ty) = \psi(t)f(y)$.

In particular, in a locally standard manifold, there is no invariant submanifold in M fixed by a discrete subgroup in T , only. Indeed, this is not supposed to happen when M is equivariantly formal over \mathbb{Z} due to Masuda and Panov ([MP03]).

Theorem 1.2.24. *The following are equivalent for a torus manifold M :*

- *The action is equivariantly formal.*
- *The action is locally standard and each face F of M^* as well as M^* itself is acyclic.*

1.2.5 GKM fibrations, GKM fiber bundles and generalized flag manifolds

This part is devoted to review the notion of a GKM fibration respectively a GKM fiber bundle, as introduced in [GSZ12], and to establish facts about generalized flag manifolds G/T , where G is a semisimple, compact and connected Lie group, and T is a maximal torus (the authors in [GHZ06] even described homogeneous spaces of the form G/H , where $H \supset T$ is compact and connected, but we will not need this). We start with the generalized flag manifolds.

Theorem 1.2.25. *The natural T -action on G/T from the left is 2-independent and equivariantly formal, thus of GKM type. There is a one-to-one correspondence between the set of T -fixpoints and $W(G)$, the Weyl group of G . Moreover, G/T admits an invariant almost-complex structure, which turns the GKM graph of G/T into a signed graph. Every signed label is a root of G .*

It is more or less standard theory that spaces of the form G/H , where H is the centralizer of a subtorus in T , even admit an invariant Kähler structure. The statement about the condition invariant almost-complex structures in [GHZ06], however, is for all homogeneous

spaces of the form G/H , where H and G have equal rank.

There is quite an explicit description for the GKM graph Γ of G/T , too. As already mentioned, the vertices are in one-to-one correspondence to $W(G)$, and two elements w and w' are connected by an edge if and only if there is a root α such that $w' = ws_\alpha$, where s_α is the reflection at the hyperplane defined by α . If so, then the label of this edge is precisely α , up to sign. In particular, any two vertices of Γ are connected by at most one edge.

There is also a canonical connection on this GKM graph Γ . For edges $e = (w, ws_\alpha)$ and $e' = (w, ws_{\alpha'})$, we define $\nabla_e e'$ as the edge $(ws_\alpha, ws_\alpha s_{\alpha'})$.

Let us now turn to GKM fibrations and GKM fiber bundles. One should note that the authors there had specific geometric examples in mind when they introduced these notions, namely geometric fiber bundles $K/H \rightarrow G/H \rightarrow G/K$, where $H \subset K \subset G$ are compact connected Lie groups of the same rank. As described in [GHZ06], the natural T -action on all of these spaces turns out to be GKM, and between any two vertices, there is at most one edge. This is why the initial definitions of GKM fibrations and GKM fiber bundles only contain graphs with exactly that property. Of course, it is quite straightforward to extend this definition to general graphs, which was done in [GKZZ20].

A morphism of graphs $\pi: \Gamma' \rightarrow B$ consists of a map π_V from $V(\Gamma')$ to $V(B)$ together with a map π_E from $E(\Gamma')$ to $E(B)$ which is compatible with π_V in the sense that $\pi_E(e)$ is an edge between $\pi_V(p)$ and $\pi_V(q)$ for all edges e between p and q (from now on, we just write π for both π_V and π_E). It is allowed that e is sent to an 'edge' (q, q) ; we call all edges with this property vertical, and all other edges horizontal. For $p \in V(\Gamma')$, we denote by H_p all horizontal edges in Γ' adjacent to p .

We say that a morphism of graphs π is a graph fibration if $\pi: H_p \rightarrow E(B)_{\pi(p)}$ is a bijection. For an edge e at $\pi(p)$, we call its unique preimage \tilde{e} under this bijection a lift of e at p . Moreover, for any vertex q of B , we denote by Γ'_q the maximal subgraph of Γ' induced by the vertex set $\pi^{-1}(q)$. Then there is a natural map $\Psi_{(q_1, q_2)}: V(\Gamma'_{q_1}) \rightarrow V(\Gamma'_{q_2})$ for any neighbored q_1, q_2 in $V(B)$, and this map is bijective with inverse $\Psi_{(q_2, q_1)}$. However, it does not have to extend to a morphism of graphs.

Definition 1.2.26. We say that a graph fibration is a fiber bundle of graphs if all $\Psi_{(q_1, q_2)}$ from above extend to isomorphisms of graphs. If so, then we just write $\Psi_{(q_1, q_2)}$ for these isomorphisms of graphs.

Now we are ready to define the notion of interest. We consider Γ' and B now as GKM graphs with their labeling α and α_B and their connections ∇ and ∇^B .

Definition 1.2.27. A graph fibration $\pi: \Gamma' \rightarrow B$ is a (signed) GKM fibration if the following hold:

1. For all $q \in V(B)$ and all edges e adjacent to q , $\alpha_B(e)$ equals $\alpha(\tilde{e})$ for any lift \tilde{e} of e at an element in $\pi^{-1}(q)$.
2. ∇_e sends horizontal to horizontal and vertical to vertical edges for any $e \in E(\Gamma')$.

3. The connections ∇ and ∇_B are compatible with lifts in the obvious sense.

Definition 1.2.28. We call a (signed) GKM fibration a (signed) GKM fiber bundle if π is a fiber bundle of graphs and

1. every $\Psi_{(q_1, q_2)}$ is compatible with the connection of Γ in the sense that $\Psi_{(q_1, q_2)}(e') = \nabla_e e'$ for all vertical edges e' of Γ'_{q_1} and lifts e of (q_1, q_2) .
2. every $\Psi_{(q_1, q_2)}$ extends to an isomorphism of GKM graphs $\Gamma'_{q_1} \rightarrow \Gamma'_{q_2}$.

1.3 Multiplicity free manifolds

We begin with some basic notions and facts from the theory of compact Lie groups. Let T be a maximal torus in the compact, connected Lie group K . We will use \mathfrak{k} and \mathfrak{t} for the Lie algebras of K and T , respectively. Furthermore \mathfrak{k}^* and \mathfrak{t}^* are the dual vector spaces, and we equip \mathfrak{k}^* with the coadjoint action of K . We can and will view \mathfrak{t}^* as a subspace of \mathfrak{k}^* using the identification

$$\mathfrak{t}^* \cong (\mathfrak{k}^*)^T \subset \mathfrak{k}^*$$

with the subspace of T -fixed vectors in \mathfrak{k}^* . We denote the weight lattice of K by Λ , that is

$$\Lambda = \text{Hom}_{\mathbb{Z}}(\ker(\exp|_{\mathfrak{t}}), \mathbb{Z}) \subset \mathfrak{t}^*,$$

where $\exp : \mathfrak{k} \rightarrow K$ is the exponential map. Note that

$$\Lambda \rightarrow \text{Hom}(T, \text{U}(1)), \nu \mapsto [\exp(\xi) \mapsto \exp(2\pi\sqrt{-1}\langle \nu, \xi \rangle)]$$

is a bijection between Λ and the character group of T , with inverse map

$$\text{Hom}(T, \text{U}(1)) \rightarrow \Lambda, \lambda \mapsto \frac{1}{2\pi\sqrt{-1}}\lambda_*,$$

where λ_* is the derivative of λ at the identity. We will use this bijection to identify Λ with $\text{Hom}(T, \text{U}(1))$. In particular, if V is a complex representation of K and $v \in V$ is a weight vector of weight $\lambda \in \Lambda$, then we have (with abuse of notation)

$$\begin{aligned} \xi \cdot v &= 2\pi\sqrt{-1}\lambda(\xi)v \text{ for all } \xi \in \mathfrak{t}, \text{ and} \\ t \cdot v &= \lambda(t)v \text{ for all } t \in T. \end{aligned}$$

Next, we let $G := K^{\mathbb{C}}$ be the complexification of K . Then G is a complex connected reductive group of which K is a maximal compact subgroup and of which the complexification $T^{\mathbb{C}}$ of T is a maximal torus. Recall that the weight lattice $\text{Hom}(T^{\mathbb{C}}, \mathbb{C}^{\times})$ of G can be identified with Λ using the restriction map

$$\text{Hom}_{\text{alg. gp.}}(T^{\mathbb{C}}, \mathbb{C}^{\times}) \rightarrow \text{Hom}_{\text{Lie gp.}}(T, \text{U}(1)), \lambda \mapsto \lambda|_T.$$

Fix a maximal unipotent subgroup N of G which is normalized by $T^{\mathbb{C}}$ and let \mathfrak{t}_+ be the (closed) Weyl chamber in \mathfrak{t}^* which is positive with respect to N . It is a fundamental domain for the coadjoint action of K on \mathfrak{t}^* and for the natural action of the Weyl group

$$W := N(T)/T$$

of K on \mathfrak{t}^* . Then

$$\Lambda^+ := \Lambda \cap \mathfrak{t}_+$$

is the monoid of dominant weights. Highest weight theory tells us that the assignment

$$V \mapsto \text{the weight of the } T\text{-action on } V^N$$

is a bijection between the set of isomorphism classes of irreducible finite-dimensional complex representations of K and Λ^+ . When $\lambda \in \Lambda^+$, we will write $V(\lambda)$ for the (up to isomorphism) unique irreducible finite-dimensional complex representation of K with highest weight λ . Furthermore, K and G have the same finite-dimensional complex representations: if $\dim_{\mathbb{C}} V < \infty$ and $\rho : K \rightarrow \text{GL}(V)$ is a homomorphism of Lie groups then there exists a unique homomorphism $\bar{\rho} : G \rightarrow \text{GL}(V)$ of algebraic groups such that $\bar{\rho}|_K = \rho$.

Example 1.3.1. To illustrate the objects we just recalled and to fix notation that we will use in what follows, we explicitly describe the objects in the case where K is the unitary group $U(2)$ of rank 2. We choose the maximal torus

$$T = \left\{ \begin{pmatrix} t_1 & 0 \\ 0 & t_2 \end{pmatrix} : t_1, t_2 \in \mathbb{C}, |t_1| = |t_2| = 1 \right\} \subset U(2).$$

The complexification of $U(2)$ is $\text{GL}(2) := \text{GL}(2, \mathbb{C})$ and that of T is

$$T^{\mathbb{C}} = \left\{ \begin{pmatrix} t_1 & 0 \\ 0 & t_2 \end{pmatrix} : t_1, t_2 \in \mathbb{C}^{\times} \right\} \subset \text{GL}(2).$$

We will write $\varepsilon_1, \varepsilon_2$ for the basis of \mathfrak{t}^* dual to the basis

$$\xi_1 := \begin{pmatrix} 2\pi\sqrt{-1} & 0 \\ 0 & 0 \end{pmatrix}, \quad \xi_2 := \begin{pmatrix} 0 & 0 \\ 0 & 2\pi\sqrt{-1} \end{pmatrix}$$

of \mathfrak{t} . Then the weight lattice is

$$\Lambda = \langle \varepsilon_1, \varepsilon_2 \rangle_{\mathbb{Z}}$$

and viewed as elements of $\text{Hom}(T, U(1))$ or of $\text{Hom}(T^{\mathbb{C}}, \mathbb{C}^{\times})$ the characters $\varepsilon_1, \varepsilon_2$ are defined by

$$\varepsilon_i \left(\begin{pmatrix} t_1 & 0 \\ 0 & t_2 \end{pmatrix} \right) = t_i \quad \text{for } i \in \{1, 2\}. \quad (1.3.1)$$

For N we choose the subgroup

$$\left\{ \begin{pmatrix} 1 & a \\ 0 & 1 \end{pmatrix} : a \in \mathbb{C} \right\}$$

of $\mathrm{GL}(2)$. The corresponding Weyl chamber is then

$$\mathfrak{t}_+ = \{\lambda \in \mathfrak{t}^* : \langle \alpha^\vee, \lambda \rangle \geq 0\},$$

where

$$\alpha^\vee := \xi_1 - \xi_2 \tag{1.3.2}$$

is the coroot of the simple root

$$\alpha := \varepsilon_1 - \varepsilon_2 \in \Lambda \subset \mathfrak{t}^* \tag{1.3.3}$$

of $\mathrm{U}(2)$ (and of $\mathrm{GL}(2)$).

The Weyl group W of $\mathrm{U}(2)$ (and of $\mathrm{GL}(2)$) is isomorphic to the symmetric group S_2 and the nontrivial element $s_\alpha \in W$ acts on \mathfrak{t}^* by the reflection

$$s_\alpha(\lambda) = \lambda - \langle \alpha^\vee, \lambda \rangle \alpha, \quad \text{where } \lambda \in \mathfrak{t}^*.$$

The monoid of dominant weights is

$$\Lambda^+ = \langle \omega_1, \omega_2, -\omega_2 \rangle_{\mathbb{N}}, \quad \text{where } \omega_1 := \varepsilon_1 \text{ and } \omega_2 := \varepsilon_1 + \varepsilon_2.$$

Observe that ω_1 is the highest weight of the standard representation of $\mathrm{U}(2)$ (or of $\mathrm{GL}(2)$), which we will usually simply denote by \mathbb{C}^2 . We will also use the notation \mathbb{C}_{\det^k} for the one-dimensional representation $V(k\omega_2)$, where $k \in \mathbb{Z}$:

$$A \cdot z = \det(A)^k z \quad \text{for all } z \in \mathbb{C}_{\det^k} \text{ and all } A \text{ in } \mathrm{U}(2) \text{ or in } \mathrm{GL}(2).$$

A **Hamiltonian K -manifold** is a triple (M, ω, μ) , where (M, ω) is symplectic manifold equipped with a smooth K -action $K \times M \rightarrow M$ and a **momentum map** μ , which means, by definition, a smooth map $\mu : M \rightarrow \mathfrak{k}^*$ that is K -equivariant with respect to the coadjoint action of K on \mathfrak{k}^* and satisfies

$$d\mu^\xi = \iota(\xi_M)\omega \quad \text{for all } \xi \in \mathfrak{k}.$$

Here ξ_M is the vector field on M defined by

$$\xi_M(x) = \left. \frac{d}{dt} \right|_{t=0} \exp(t\xi) \cdot x \in T_x M, \quad \text{where } x \in M,$$

and $\mu^\xi : M \rightarrow \mathbb{R}$ is the function with $\mu^\xi(m) = \mu(m)(\xi)$. Since we have identified the Weyl chamber \mathfrak{t}_+ with a subset of \mathfrak{k}^* we can define

$$\mathcal{P}(M) := \mu(M) \cap \mathfrak{t}_+. \tag{1.3.4}$$

In [Kir84, Theorem 2.1], F. Kirwan proved that $\mathcal{P}(M)$ is the convex hull of finitely many points when M is compact and connected. In that case we call $\mathcal{P}(M)$ the **momentum polytope** of M .

Example 1.3.2 describes an important source of Hamiltonian K -manifolds: projective spaces $\mathbb{P}(V)$ associated to unitary representations V of K .

Example 1.3.2. Let V be a finite-dimensional unitary representation of K with K -invariant Hermitian inner product $\langle \cdot, \cdot \rangle$, where we adopt the convention that $\langle \cdot, \cdot \rangle$ is complex-linear in the first entry. Following [Sja98, Ex. 2.1 and 2.2], we describe well-known structures of Hamiltonian K -manifolds on V and on the associated projective space $\mathbb{P}(V)$, which is the space of complex lines in V . The map

$$\mu_V : V \rightarrow \mathfrak{k}^*, \mu_V(v)(\xi) = \frac{\sqrt{-1}}{2} \langle \xi v, v \rangle, \quad (1.3.5)$$

where $\xi \in \mathfrak{k}$, is a momentum map for the K -invariant symplectic form $\omega_V(\cdot, \cdot) = -\text{Im}\langle \cdot, \cdot \rangle$ on V . The Fubini-Study symplectic form $\omega_{\mathbb{P}(V)}$ on $\mathbb{P}(V)$ corresponding to $\langle \cdot, \cdot \rangle$ is invariant under the natural K -action on $\mathbb{P}(V)$ and we equip $\mathbb{P}(V)$ with the momentum map

$$\mu_{\mathbb{P}(V)} : \mathbb{P}(V) \rightarrow \mathfrak{k}^*, \mu_{\mathbb{P}(V)}([v])(\xi) = \frac{\sqrt{-1}}{2\pi} \frac{\langle \xi v, v \rangle}{\|v\|^2}, \quad (1.3.6)$$

where $\xi \in \mathfrak{k}$ and $[v]$ is the complex line through $v \in V \setminus \{0\}$.

If K is a torus and $v \in V$ is a weight vector with weight λ , then $\mu_V(v) = -\pi\|v\|^2 v$ and $\mu_{\mathbb{P}(V)}([v]) = -\lambda \in \mathfrak{k}^*$. This implies that

$$\mu_V(V) = -\text{cone}\{\lambda_1, \lambda_2, \dots, \lambda_r\} \quad (1.3.7)$$

and that the momentum polytope of $(\mathbb{P}(V), \mu_{\mathbb{P}(V)})$ is

$$\mathcal{P}(\mathbb{P}(V)) = \mu_{\mathbb{P}(V)}(\mathbb{P}(V)) = -\text{conv}(\lambda_1, \lambda_2, \dots, \lambda_r), \quad (1.3.8)$$

where $\lambda_1, \lambda_2, \dots, \lambda_r$ are the weights of K in V .

The following Theorem, which is due to Sjamaar and which was extracted from [Sja98] will be useful in section 4.2. In order to state it, we recall that the *symplectic slice* of a Hamiltonian K -manifold M in $m \in M$ is the symplectic vector space

$$N_m := (T_m(K \cdot m))^\perp / (T_m(K \cdot m) \cap (T_m(K \cdot m))^\perp), \quad (1.3.9)$$

where $(T_m(K \cdot m))^\perp$ is the symplectic annihilator of $T_m(K \cdot m)$ in $T_m M$. The isotropy action of K_m on $T_m M$ induces a natural symplectic representation of K_m on N_m .

Theorem 1.3.3 ([Sja98]). *Let (M, μ) be a compact connected Hamiltonian K -manifold.*

(a) *If $m \in M$ such that $\mu(m)$ is a vertex of $\mathcal{P}(M)$ lying in the interior of \mathfrak{t}_+ , then $K_m = T$.*

(b) *Let $m \in M$ such that $\mu(m)$ lies in the interior of \mathfrak{t}_+ and $K_m = T$. Then*

$$N_m = (T_m(K \cdot m))^\perp \cong T_m M / T_m(K \cdot m) \quad (1.3.10)$$

as T -modules, where N_m is the symplectic slice of M in m . If Π_m is the set of weights of the symplectic T -representation N_m , then the cone with vertex $\mu(m)$ spanned by $\mathcal{P}(M)$ is equal to $\mu(m) - \text{cone } \Pi_m$.

Proof. Assertion (a) is contained in part 2. of [Sja98, Theorem 6.7]. Assertion (b) follows from part 1. of *loc.cit.* and from (1.3.7) above; see also the paragraph in [Sja98] containing Equation (6.9). To apply (1.3.7) to the symplectic T -representation N_m we recall that any symplectic T -representation (V, ω_V) can be made into a unitary representation by choosing a T -invariant complex structure on V that is compatible with the symplectic form ω_V and that the weights of the representation are independent of this choice. \square

Remark 1.3.4. In both parts of this remark, the point $m \in M$ is as in part (b) of theorem 1.3.3.

- (a) The cone with vertex $\mu(m)$ spanned by $\mathcal{P}(M)$ is not pointed when $\mu(m)$ is not a vertex of $\mathcal{P}(M)$ (we recall that a cone is called *pointed* when it does not contain any line).
- (b) Later in this paper we will use that there exists a K -invariant diffeomorphism φ from the homogeneous fiber bundle $K \times_T N_m$ onto a K -invariant neighborhood of $K \cdot m$ in M such that $\varphi([e, 0]) = m$ (we recall the construction of $K \times_T N_m$ below in proposition 1.4.1). This is an application of the slice theorem (see, e.g., [Kaw91, Theorem 4.10]). Actually, the proof of theorem 1.3.3(b) uses the *symplectic* slice theorem of Marle [Mar88] and Guillemin-Sternberg [GS90] (see, e.g., [Sja98, Theorem 6.3] for a statement of this theorem).

We will also make use of the following well-known fact. For a proof, see, e.g., [GS05, Theorems 1.2.1 and 1.2.2].

Proposition 1.3.5. *Let (M, ω, μ) be a compact connected Hamiltonian K -manifold with momentum polytope $\mathcal{P}(M)$ and let $r : \mathfrak{k}^* \rightarrow \mathfrak{t}^*$ be the dual map to the inclusion $\mathfrak{t} \rightarrow \mathfrak{k}$. Then $(M, \omega, r \circ \mu)$ is a Hamiltonian T -manifold whose momentum polytope $\mathcal{P}_T(M) := r(\mu(M))$ satisfies the equality*

$$\mathcal{P}_T(M) = \text{conv} \left(\bigcup_{w \in W} w \cdot \mathcal{P}(M) \right). \quad (1.3.11)$$

Definition 1.3.6. A **multiplicity free K -manifold** is a *compact and connected* Hamiltonian K -manifold M such that

$$\mu^{-1}(a)/K_a \text{ is a point for every } a \in \mu(M). \quad (1.3.12)$$

Remark 1.3.7. (a) We have included connectedness and compactness in the definition of a multiplicity free K -manifold to avoid having to frequently repeat the associated adjectives in this paper. The (more general) notion of multiplicity free Hamiltonian manifold was introduced in [MF78] and [GS84] as a Hamiltonian K -manifold M of which the Poisson algebra of K -invariant smooth functions $M \rightarrow \mathbb{R}$ is an abelian Lie algebra. Equivalent conditions on M are given in [HW90, Theorem 3]. As shown in [Woo96, Proposition A.1], for a compact, connected Hamiltonian K -manifold M this original definition is equivalent to condition (1.3.12).

- (b) Let (M, ω, μ) be a compact connected Hamiltonian K -manifold. As observed in [Kno11], just after Definition 2.1, M is multiplicity free if and only if

$$M/K \rightarrow \mathcal{P}(M) : K \cdot m \mapsto \mu(K \cdot m) \cap \mathfrak{t}_+$$

is a homeomorphism. Furthermore, if the principal isotropy group of the K -action on M is discrete, then M is multiplicity free if and only if

$$\dim(M) = \dim(K) + \text{rk}(K), \quad (1.3.13)$$

see [Woo96, Proposition A.1].

In order to state Knop's classification theorem for multiplicity free manifolds we introduce some additional notation and recall some more well-known facts. A smooth affine complex G -variety X is called **spherical** if its ring of regular functions $\mathbb{C}[X]$ is multiplicity free as a G -module, that is

$$\dim \text{Hom}^G(V(\lambda), \mathbb{C}[X]) \leq 1 \text{ for all } \lambda \in \Lambda^+.$$

The **weight monoid** $\Gamma(X)$ of X is the set of highest weights of $\mathbb{C}[X]$, that is

$$\Gamma(X) := \{ \lambda \in \Lambda^+ : \text{Hom}^G(V(\lambda), \mathbb{C}[X]) \neq \{0\} \}.$$

As proved by Losev in [Los09, Theorem 1.3], a smooth affine spherical G -variety X is uniquely determined by $\Gamma(X)$, up to G -equivariant isomorphism. If $a \in \mathfrak{t}_+ \subset \mathfrak{k}^*$ then the complexification $K_a^{\mathbb{C}}$ of the stabilizer K_a of a is a complex connected reductive subgroup of G . Since K_a contains T its weight lattice is still Λ . The Weyl chamber of K_a and $K_a^{\mathbb{C}}$ corresponding to the maximal unipotent subgroup $N \cap K_a^{\mathbb{C}}$ of $K_a^{\mathbb{C}}$ is $\mathbb{R}_{\geq 0}(\mathfrak{t}_+ - a) \subset \mathfrak{k}^*$.

Example 1.3.8. We take $K = \text{U}(2)$ and use the notation of example 1.3.1. If $a \in \mathfrak{t}_+$ then

$$K_a^{\mathbb{C}} = \begin{cases} \text{GL}(2) & \text{if } \langle \alpha^\vee, a \rangle = 0; \\ T^{\mathbb{C}} & \text{if } \langle \alpha^\vee, a \rangle > 0 \end{cases}$$

and the corresponding positive Weyl chamber of $K_a^{\mathbb{C}}$ is

$$\mathbb{R}_{\geq 0}(\mathfrak{t}_+ - a) = \begin{cases} \mathfrak{t}_+ & \text{if } \langle \alpha^\vee, a \rangle = 0; \\ \mathfrak{k}^* & \text{if } \langle \alpha^\vee, a \rangle > 0 \end{cases}$$

We can now specialize Knop's Theorems 10.2 and 11.2 from [Kno11] to the case of compact connected multiplicity free Hamiltonian manifolds with trivial principal isotropy group.

Theorem 1.3.9 (Knop). (a) *Suppose (M, ω_M, μ_N) and (N, ω_N, μ_N) are multiplicity free K -manifolds with trivial principal isotropy group. If $\mathcal{P}(M) = \mathcal{P}(N)$, then there exists a K -equivariant symplectomorphism $\varphi : M \rightarrow N$ such that $\mu_N \circ \varphi = \mu_M$.*

- (b) Let \mathcal{Q} be a convex polytope in \mathfrak{t}_+ . There exists a multiplicity free K -manifold M with trivial principal isotropy group such that $\mathcal{P}(M) = \mathcal{Q}$ if and only if for every vertex a of \mathcal{Q} there exists a smooth affine spherical $(K_a)^\mathbb{C}$ -variety X_a such that

$$\Gamma(X_a) \text{ generates the weight lattice } \Lambda \text{ as a group, and} \quad (1.3.14)$$

$$\mathcal{Q} - a \text{ and } \Gamma(X_a) \text{ generate the same convex cone in } \mathfrak{t}^*. \quad (1.3.15)$$

Remark 1.3.10. (a) The fact that the principal isotropy group of the K -action on M is trivial is encoded in condition (1.3.14) of theorem 1.3.9. Knop’s classification result [Kno11, Theorem 11.2] makes no restrictions on the principal isotropy group, which is encoded as a sublattice of Λ .

- (b) Part (a) of theorem 1.3.9 is a special case of a conjecture due to Th. Delzant. He proved his conjecture when K is a torus in [Del88] and when $\text{rk}(K) = 2$ in [Del90]. Knop proved it in general in [Kno11, Theorem 10.2].
- (c) Thanks to [PVS19], the criterion in part (b) of theorem 1.3.9 can be checked combinatorially (or algorithmically), i.e. without having to actually produce the spherical varieties X_a . On the other hand, in section 4.1 below we will distill from [PPVS18] all smooth affine spherical $\text{GL}(2)$ -varieties X such that $\Gamma(X)$ generates Λ as a group and the convex cone generated by $\Gamma(X)$ is pointed.
- (d) Referring to [Kno11, Section 2] for details, we briefly sketch how the $(K_a)^\mathbb{C}$ -variety X_a yields a “local model” of the manifold M as in theorem 1.3.9(b). One can define a structure of Hamiltonian K -manifold on the homogeneous fiber bundle $K \times_{K_a} X_a$ such that a K -stable open subset of $K \times_{K_a} X_a$ is isomorphic (as a Hamiltonian K -manifold) to a neighborhood of the K -orbit $\mu^{-1}(K \cdot a)$ in M .

1.4 Homogeneous fiber bundles

To explicitly describe multiplicity free $\text{U}(2)$ -manifolds in section 4.2, we will make use of *homogeneous fiber bundles*, which are also known as *associated bundles* or *twisted products*. We recall their basic properties in the category of differentiable manifolds, then in that of algebraic varieties, and finally state a comparison result that we will need later.

If G is group, H is a subgroup of G and F is a set on which H acts, then we denote by $G \times_H F$ the quotient set of $G \times F$ for the following action of H

$$h \cdot (g, f) = (gh^{-1}, h \cdot f) \quad \text{for } g \in G, h \in H, f \in F. \quad (1.4.1)$$

As the left action of G on $G \times F$, $g \cdot (g', f) = (gg', f)$ commutes with this action of H , we obtain a G -action on $G \times_H F$. We will use π for the G -equivariant quotient map

$$\pi : G \times F \rightarrow G \times_H F, (g, f) \mapsto [g, f]$$

and p for the (well-defined) G -equivariant map

$$p : G \times_H F \rightarrow G/H, [g, f] \mapsto gH.$$

We begin with standard facts about the “differentiable” version of $G \times_H F$ and sketch a proof for the sake of completeness.

Proposition 1.4.1. *Let G be a compact connected Lie group, H a closed subgroup and F a manifold equipped with a smooth action of H . Then the following hold:*

(a) $G \times_H F$ admits a unique structure as a manifold such that

- (i) $\pi : G \times F \rightarrow G \times_H F$ is a smooth map; and
- (ii) for an arbitrary manifold N a map $h : G \times_H F \rightarrow N$ is smooth if and only if $h \circ \pi$ is smooth.

When $G \times_H F$ is equipped with this structure, the map $p : G \times_H F \rightarrow G/H$ and the action map $G \times (G \times_H F) \rightarrow G \times_H F$ are smooth;

(b) If $f : M \rightarrow G/H$ is a smooth G -equivariant map, where M is a manifold equipped with a smooth action of G , and $A = f^{-1}(eH)$, then A is a smooth H -invariant submanifold of M and the map

$$G \times_H A \rightarrow M, [g, a] \mapsto g \cdot a$$

is a G -equivariant diffeomorphism, if $G \times_H A$ carries the manifold structure of part (a).

Proof. The characterization of the manifold structure on $G \times_H F$ in part (a) is a consequence of the basic fact that the quotient of a manifold under a free action of a compact Lie group is a manifold; see, for instance, [Kaw91, Theorem 4.11]. That p is smooth now follows, because $p \circ \pi : G \rightarrow G/H, g \mapsto gH$ is a smooth map, see e.g. [Kaw91, Theorem 3.37]. Furthermore, the aforementioned Theorem 4.11 in [Kaw91] also tells us that π has smooth local cross-sections, from which one can deduce that the action map is smooth. We turn to part (b). One observes that eH is a regular value of f , that the two manifolds $G \times_H A$ and M have the same dimension and that the given map $G \times_H A \rightarrow M$ is G -equivariant and injective. With standard arguments, one then shows that the map’s differential is surjective everywhere. \square

Before stating an algebraic version of proposition 1.4.1 we recall that if H is a closed algebraic subgroup of a linear algebraic group G , then the coset space G/H carries a unique structure of algebraic variety such that the canonical surjection $G \rightarrow G/H$ is a so-called geometric quotient for the action of H on G from the right. Equipped with this structure, as it always will be, G/H is a smooth quasi-projective variety and the action map

$$G \times (G/H) \rightarrow G/H, (g, g'H) \mapsto gg'H$$

is a morphism of algebraic varieties (see, for example, [TY05, 25.4.7 and 25.4.10]).

The following proposition, which summarizes properties of the “algebraic” homogeneous fiber bundle, is extracted from [PV94, Section 4.8]; see also [Tim11, Theorem 2.2].

Proposition 1.4.2. *Let G be a complex connected reductive linear algebraic group, H a closed algebraic subgroup and F a smooth quasi-projective H -variety. Equip $G \times_H F$ with the quotient Zariski-topology (i.e. the coarsest topology which makes $\pi : G \times F \rightarrow G \times_H F$ continuous, where $G \times F$ carries the Zariski-topology) and with the sheaf \mathcal{O} which is the direct image under π of the sheaf of H -invariant regular functions on $G \times F$. Then the following hold:*

- (a) *The ringed space $(G \times_H F, \mathcal{O})$ is a smooth complex algebraic variety;*
- (b) *The maps π and p and the action map $G \times (G \times_H F) \rightarrow G \times_H F$ are morphisms of algebraic varieties.*

The next proposition recalls a standard fact in the theory of complex algebraic varieties, see [Ser56, Nr. 5]

Proposition 1.4.3. (a) *If X is a smooth complex algebraic variety, then X admits a unique structure as a complex manifold such that every algebraic chart of X is a holomorphic chart. We write X^h for X equipped with this structure of complex manifold.*

- (b) *If X and Y are smooth complex algebraic varieties and $f : X \rightarrow Y$ a morphism of algebraic varieties, then $f : X^h \rightarrow Y^h$ is holomorphic.*

A complex manifold carries a natural structure of a differentiable manifold, by viewing the holomorphic charts as \mathcal{C}^∞ -charts. Thus proposition 1.4.3 also equips every smooth algebraic variety with a structure of differentiable manifold, which we will call **standard**. Whenever we view a smooth algebraic variety as a differentiable manifold it will be equipped with this standard structure. In section 4.2 we will make use of the following comparison result. We include a proof for completeness.

Proposition 1.4.4. *Consider the subgroup*

$$B^- := \left\{ \begin{pmatrix} a & 0 \\ c & d \end{pmatrix} : a, c, d \in \mathbb{C}, ad \neq 0 \right\} \quad (1.4.2)$$

of $\mathrm{GL}(2)$ and recall the torus $T \subset \mathrm{U}(2)$ from example 1.3.1. If F is a smooth quasi-projective B^- -variety and we equip $\mathrm{GL}(2) \times_{B^-} F$ with its standard structure as a differentiable manifold, then

$$\mathrm{U}(2) \times_T F \rightarrow \mathrm{GL}(2) \times_{B^-} F, [g, f] \mapsto [g, f] \quad (1.4.3)$$

is a $\mathrm{U}(2)$ -equivariant diffeomorphism.

Proof. We equip $\mathrm{GL}(2)$ and $\mathrm{GL}(2)/B^-$ with their standard structures as differentiable manifolds. Then $\mathrm{U}(2)$ is a closed subgroup of the Lie group $\mathrm{GL}(2)$. The inclusion $\mathrm{U}(2) \rightarrow \mathrm{GL}(2)$ induces a transitive smooth action of $\mathrm{U}(2)$ on $\mathrm{GL}(2)/B^-$. Since $B^- \cap \mathrm{U}(2) = T$ we thus obtain —using [Kaw91, Corollary 4.4] for example— a $\mathrm{U}(2)$ -equivariant diffeomorphism $\mathrm{U}(2)/T \rightarrow \mathrm{GL}(2)/B^-$. Let $\varphi : \mathrm{GL}(2)/B^- \rightarrow \mathrm{U}(2)/T$ be the inverse diffeomorphism and recall the map

$$p : \mathrm{GL}(2) \times_{B^-} F \rightarrow \mathrm{GL}(2)/B^-, [g, f] \rightarrow gB^-.$$

Then $\varphi \circ p : \mathrm{GL}(2) \times_{B^-} F \rightarrow \mathrm{U}(2)/T$ is a $\mathrm{U}(2)$ -equivariant smooth map. The claim now follows from (b) in proposition 1.4.1. \square

Remark 1.4.5. The argument for proposition 1.4.4 actually yields the following more general fact. Suppose K is a compact connected Lie group and G its complexification. Let T be a maximal torus of K and B be a Borel subgroup of G containing T . If F is a quasi-projective B -variety and we equip $G \times_B F$ with its standard structure as a differentiable manifold, then

$$K \times_T F \rightarrow G \times_B F, [k, f] \mapsto [k, f]$$

is a K -equivariant diffeomorphism.

Chapter 2

Label extension and realization of 3-valent GKM graphs

The realization of GKM graphs, that is, the construction of a GKM manifold with a given GKM graph, is a huge unsolved problem. While there are certain obstructions to realizing a graph (see [AMS22]), there are no sufficient conditions for arbitrary valency up to now. Figuring that it might make sense to think about the realization problem in low dimensions respectively low valency of the graph, Goertsches, Konstantis and Zoller in fact did realize certain GKM graphs of valency 3, the lowest interesting case, in [GKZ22]. They were able to show that a rather general graph theoretic obstruction to realization, namely that the GKM graph is supposed to satisfy Poincaré duality, is also sufficient for a realization as a rational GKM manifold.

An important feature for the realization of 3-valent GKM graphs is that the orbit space of the corresponding (simply-connected) T^2 -manifold is homeomorphic to S^4 . Of course, the orbit space of a GKM manifold in arbitrary dimensions is not a sphere, not even a manifold. Therefore, it seems plausible to try to generalize the results in [GKZ22] to the realization of those graphs that do have the property that they, in principle, could be realized as a T -manifold whose orbit space is a manifold. These n -valent graphs turn out to be precisely the GKM_{n-1} -graphs by [A18], or also known as graphs in general position. In [AM19], it was shown that the orbit space of an equivariantly formal (over \mathbb{Q}) T -manifold with such a graph does have the property that its orbit space has the rational homology of a sphere, and it was shown that this also holds over \mathbb{Z} for connected stabilizers (in this case, the orbit space is even a manifold, and thus an integer homology sphere). Also, a kind of converse was proven ([AM19, Theorem 4]): if a T -manifold is given whose stabilizers are connected, whose orbit space is a rational homology sphere and which satisfies certain other necessary conditions, then the T -manifold is equivariantly formal over \mathbb{Q} .

In this chapter, we first show that a 4-independent graph, if it satisfies certain conditions necessary for realization, is in fact the restriction of a torus graph. This can be used, for example, to study equivariantly formal manifolds in general position (although we do not do this here, in generality).

After that, and not related to the part before, we prove a converse of [AM19, Theorem 4] for $n = 3$ and \mathbb{Z} -coefficients, which, in turn, enables us to realize every orientable 3-valent GKM graph with (signed or unsigned) \mathbb{Z}^2 -labeling as an equivariantly formal (over \mathbb{Z}) T^2 -manifold, using the construction in [GKZ22].

2.1 Label extension of certain GKM graphs

The main result of this small section is theorem 2.1.3, which states that certain 4-independent GKM graphs are actually restrictions of a torus graph. The main assumption is that the fundamental group of Γ is generated by connection paths. This assumption is quite natural in view of theorem 1.2.21: if Γ was realizable as an equivariantly formal (even only over \mathbb{Q}) GKM manifold M , then it would follow that $b_1(M_2^*) = 0$, which is equivalent to the statement that $H_1(\Gamma; \mathbb{Q})$ is generated by connection paths. We will see in remark 2.1.2 that this, in turn, is equivalent to the same statement on fundamental groups.

Let us begin with a more fundamental concept, for which we do not need the 4-independency yet.

Lemma 2.1.1. *Let Γ be an n -valent GKM graph with the following properties:*

1. *Any connection path is a two-valent GKM subgraph.*
2. *The group $\pi_1(\Gamma)$ is generated by connection paths.*

Then there is a maximal contractible tree $T \subset \Gamma$ together with an ordered tuple of edges $e_1, \dots, e_k = E(\Gamma) \setminus E(T)$ such that attaching e_1 to T closes a connection path, attaching e_2 on $T \cup e_1$ closes a connection path, \dots , attaching e_k on $\Gamma \setminus e_k$ closes a connection path.

Proof. We denote by \mathcal{G}_1 the set of all connection paths of Γ , ordered increasingly by the number of their edges. Take any the first connection path γ_1 of \mathcal{G}_1 and remove an edge. This will be e_1 . Now set $\Gamma_2 := \Gamma / \gamma_1$, and let \mathcal{G}_2 be the set of all non-trivial (that is, non-constant paths) descensions of elements of \mathcal{G}_1 , ordered by number of edges. Γ_2 is homotopy equivalent to $\Gamma \setminus e_1$, and we claim that the elements of \mathcal{G}_2 generate the fundamental group of Γ_2 . To see this, we need to check that no connection path γ in Γ_1 except γ_1 descends to a point in Γ_2 . This is true as long as not all edges of γ collapse. If γ has more edges than γ_1 , this is clear. If γ has the same amount of edges, then these would have been precisely those of γ_1 , so $\gamma = \gamma_1$.

Now take the first element $\gamma'_2 \in \mathcal{G}_2$ and remove an edge e'_2 of γ'_2 . There is a corresponding $\gamma_2 \subset \Gamma$ (which might possibly intersect e_1) and a corresponding edge e_2 in γ_2 , which is not contained in γ_1 . Therefore, putting e_1 inside $\Gamma \setminus (e_1 \cup e_2)$ still closes a connection path, and so does putting e_2 inside $\Gamma \setminus e_2$. Now set $\Gamma_3 := \Gamma_2 / \gamma'_2$, which is homotopy equivalent to $\Gamma \setminus (e_1 \cup e_2)$, define \mathcal{G}_3 as usual, and so on. Once again, \mathcal{G}_3 generates the fundamental group of Γ_3 by the same argument as before.

We may repeat these arguments until some Γ_{k+1} is contractible (which eventually has to happen before \mathcal{G}_k becomes empty, because $\pi_1(\Gamma)$ is generated by connection paths). The ordered tuple (e_1, \dots, e_k) then has the desired properties. \square

Remark 2.1.2. Under the assumption that each connection path is a two-valent GKM subgraph, the assumption that $\pi_1(\Gamma)$ is generated by connection paths is implied by (and thus equivalent to) the assumption that $H_1(\Gamma; \mathbb{Q})$ is generated by connection paths. Indeed, by the same process as in the proof of lemma 2.1.1, $b_1(\Gamma_{k+1})$ eventually has to become 0, which, since Γ_{k+1} is a graph, implies that Γ_{k+1} is contractible.

Consider a two-valent GKM subgraph γ of Γ and fix a vertex $v \in V(\gamma)$. Denote by $F(v)$ the set $E(\Gamma)_v \setminus E(\gamma)_v$. When taking an edge in $F(v)$ and pushing this one time around γ with the connection, we get a bijection $\mu_\gamma: F(v) \rightarrow F(v)$, the monodromy map of γ . Note that this is trivial for all γ if the Graph is at least 4-independent, and that in this case, any two edges at one vertex determine a unique two-valent GKM subgraph. We want to prove the following theorem.

Theorem 2.1.3. *Let Γ be an n -valent 3-independent GKM graph with the property that any three edges belong to a unique 3-valent GKM-subgraph and that the group $\pi_1(\Gamma)$ is generated by two-valent GKM subgraphs. Then the \mathbb{Z}^k -labeling (respectively $\mathbb{Z}^k / \pm 1$) extends to an effective \mathbb{Z}^n -labeling (respectively $\mathbb{Z}^n / \pm 1$).*

Proof. We do this in the signed case, the unsigned case is analogous. We begin by noting three things.

- For every maximal contractible tree $T \subset \Gamma$, there is an extension by extending at one vertex and then pushing this over whole T via the connection.
- By the same reasoning, whenever there is an extension, it is uniquely determined by the extension at one vertex.
- At any vertex, any three edges e_1, e_2 and e_3 define a unique 3-valent, 3-independent subgraph Γ' . We can extend the labeling $\alpha(e_i)$ on this vertex to a \mathbb{Z}^n -labeling $(\alpha(e_i), 0) \in \mathbb{Z}^k \times \mathbb{Z}^{n-k}$ and this clearly gives a well-defined extension on Γ' . It follows that any three labels $\alpha'(e_i) \in \mathbb{Z}^n$ give a well-defined \mathbb{Z}^n -labeling on Γ' , since the GKM condition is linear and there is an isomorphism $\mathbb{Q}^n \rightarrow \mathbb{Q}^n$ sending $(\alpha(e_i), 0)$ to $\alpha'(e_i)$. In particular, for any connection path γ , there is an extension of the labeling on all edges meeting γ . Indeed, we may extend the \mathbb{Z}^k -labeling at some vertex to an effective \mathbb{Z}^n -labeling, and this will give a well-defined effective labeling on every 3-valent GKM-subgraph that contains γ , so in particular a well-defined labeling on all edges meeting γ .

Now choose a maximal contractible tree T as in lemma 2.1.1 (which is possible, because any two adjacent edges belong to a unique two-valent GKM subgraph by our assumption), choose an extension at some vertex of T and consider the induced extension on whole T . Normally, when attaching e_1 , this extension of T might not be compatible. But here, we close a connection path γ_1 when attaching e_1 , so by the remark above, the GKM-condition at e_1 is indeed fulfilled. When attaching e_2 , we close a connection path, again, so the GKM condition is fulfilled, and so on. This shows that the GKM condition holds everywhere on Γ , which we wanted to prove. \square

In particular, every realizable GKM graph which is at least 4-independent comes from an n -independent GKM graph, since for GKM₄-manifolds M we have $b_1(M_2^*) = \pi_1(M_2^*) = 0$, so $M_1^* = \Gamma$ has its fundamental group generated by two-valent subgraphs.

2.2 A sufficient criterion for equivariant formality and 3-valent GKM graphs

Here, we formulate and prove a sufficient criterion for equivariant formality.

Theorem 2.2.1. *Consider a GKM action of T^2 on the compact manifold M of dimension 6, such that*

- *the orbit space is a homology sphere over \mathbb{Z} .*
- *for every finite group H , every connected component of M^H contains a fixpoint.*
- *the orbit space of an arbitrary isotropy submanifold is a disk.*

Then M is equivariantly formal over \mathbb{Z} .

In the following, we write Z for the isotropy submanifolds of $N := M \setminus (M'_1 \setminus X)$. Every component hits X non-trivially, so we can set $\partial Z = X \cap Z$, which is a union of $S^1 \times T^2$'s. This follows from the assumption that any component of Z contains a fixpoint.

Let C be a connected component of Z , and $H \subset T$ be its stabilizer. The boundary E of a small closed neighborhood of C is equivariantly diffeomorphic to $C \times_H S^1$, since $C^* = D^2$ is contractible and the normal fiber over a torus orbit is of that form. This directly implies that H is cyclic, because it necessarily acts freely on S^1 . Note also that the T -action on E is free over an orbit space homotopy equivalent to S^1 , so we may also write $E = C^* \times S^1 \times T$, T acting only on the right factor. In this description, the natural map $E \rightarrow C$ is a bundle map (viewing both spaces as non-principal T^2 -bundles), but restricted to T it is only a covering, not a diffeomorphism! In particular, the map in homology between the fibers (see lemma 1.1.3) is not an isomorphism, but only an injection.

The corresponding map on orbit spaces $E^* = C^* \times S^1 \rightarrow C^*$ in this description, however, is the usual projection. We will also write $E = Z^* \times S^1 \times T$ for the boundary of a small closed neighborhood of Z in N .

Before proving theorem 2.2.1, we need a small lemma, first.

Lemma 2.2.2. $\pi_1(M) \rightarrow \pi_1(M^*)$ *is an isomorphism.*

Proof. We consider M'_1 and $X := X_1$ for the manifold M , see remark 1.2.10, We set $N := M \setminus (M'_1 \setminus X)$. It suffices to show that $\pi_1(N) \rightarrow \pi_1(N^*)$ is an isomorphism by dimensional reasons. It is standard theory that this map is surjective, and we may assume by transversality that a loop γ in its kernel only hits free orbits N_{free} . If γ is in the kernel of $\pi_1(N_{free}) \rightarrow \pi_1(N_{free}^*)$, it is in a torus orbit and we are done (because these can be homotoped to a point in M). If

not, then the image of γ is in the kernel of $\pi_1(N_{free}^*) \rightarrow \pi_1(N^*)$ and thus can be homotoped into X_{free}^* , to be in the kernel of $\pi_1(X_{free}^*) \rightarrow \pi_1(X^*)$. The kernel of $\pi_1(X_{free}^*) \rightarrow \pi_1(X^*)$ is generated by the loop in the fiber of $S^1 \rightarrow Y_1^* \rightarrow B_1$ (see remark 1.2.11). Indeed, let S be a connected component of the isotropy submanifolds of X . Then $S^* = S^1$ with trivial normal bundle $S^1 \times D^2$, so the kernel of $\pi_1((X \setminus S)^*) \rightarrow \pi_1(X^*)$ is generated by $\{pt.\} \times S^1 \subset S^1 \times D^2$. This is clearly a fiber of $S^1 \rightarrow Y_1^* \rightarrow B_1$, so we can iterate this and see that γ is again homotopic to a loop contained in a torus orbit. \square

Now we can come to the proof of theorem 2.2.1.

Proof. We have already shown that $\pi_1(M) = \pi_1(M^*)$, so $H_1(M) = H_1(M^*) = 0$. Hence, $H^1(M; \mathbb{Z}_2) = 0$, which implies that M is orientable. By Poincaré duality, $H^{odd}(M) = H_{odd}(M)$, and we show that the latter is 0. It is only left to show that $H_3(M) = 0$. Set $N := M \setminus (M'_1 \setminus X)$, where M'_1 and $X := X_1$ are as in remark 1.2.10. By $H_*(M^*) = H_*(S^4)$ and the Mayer Vietoris sequence belonging to $M^* = M'_1 \cup N^*$, we see that the interesting homology of N^* is concentrated in degree 2 ($H_3(N) = H^1(N^*/X^*) = 0$ because of Lefschetz duality) and that $H_2(X^*) \rightarrow H_2(N^*)$ is an isomorphism.

We only need to show that $H_3(X) \rightarrow H_3(N)$ is surjective because of

$$\dots \rightarrow H_3(X) \rightarrow H_3(M_1) \oplus H_3(N) \rightarrow H_3(M) \rightarrow H_2(X) \rightarrow H_2(M_1) \oplus H_2(N) \rightarrow \dots,$$

$H_3(M_1) = 0$ and $H_2(X) \rightarrow H_2(M_1)$ being an isomorphism (see remark 1.2.5). If the action on N was free, this would be an immediate consequence of the isomorphism (we only need it to be a surjection) $H_2(X^*) \rightarrow H_2(N^*)$ and the Serre spectral sequence. Indeed, $E_{p,*}^2(X) \rightarrow E_{p,*}^2(N)$ is a surjection for $p = 2$ and an injection (even an isomorphism) for $p = 0$, so $\ker(d_{2,*}^2(X)) \rightarrow \ker(d_{2,*}^2(N))$ is a surjection (remember that, for homology, $d_{p,q}^r$ goes to $E_{p-r,q+r-1}^r$) and thus $E_{2,*}^3(X) \rightarrow E_{2,*}^3(N)$ is. Also, $E_{0,*}^3(X) \rightarrow E_{0,*}^3(N)$ is an injection, then. Due to degree reasons, $E_{2,*}^3(X) = E_{2,*}^\infty(X)$ and the same for N . Now the claim follows by $H_3(N) = E_{2,1}^\infty(N)$.

In case of the action not being free, we denote by Z the isotropy submanifolds in N (whose orbit spaces are disks) and consider the diagram for the orbit spaces

$$\begin{array}{ccccccc} H_2((X \setminus \partial Z)^*) \oplus H_2(\partial Z^*) & \longrightarrow & H_2(X^*) & \xrightarrow{\partial_2} & H_1(\partial Z^* \times S^1) & \xrightarrow{i_1} & H_1((X \setminus \partial Z)^*) \oplus H_1(\partial Z^*) \\ \downarrow & & \downarrow & & \downarrow & & \downarrow \\ H_2((N \setminus Z)^*) \oplus 0 & \longleftarrow & H_2(N^*) & \xrightarrow{\partial_2} & H_1(Z^* \times S^1) & \xrightarrow{i_2} & H_1((N \setminus Z)^*) \oplus 0 \end{array}$$

and the diagram for the total spaces

$$\begin{array}{ccccccc} H_3(X \setminus \partial Z) \oplus H_3(\partial Z) & \longrightarrow & H_3(X) & \xrightarrow{\partial_3} & H_2(\partial E) & \longrightarrow & H_2(X \setminus \partial Z) \oplus H_2(\partial Z) \\ \downarrow & & \downarrow & & \downarrow & & \downarrow \\ H_3(N \setminus Z) \oplus 0 & \longleftarrow & H_3(N) & \xrightarrow{\partial_3} & H_2(E) & \longrightarrow & H_2(N \setminus Z) \oplus H_2(Z) \end{array}$$

We wrote 0 for the terms of $H_*(Z^*)$ respectively $H_*(Z)$ that are 0, because Z^* is a union of discs and Z is topologically a union of $D^2 \times T^2$'s.

In the above diagram, we see by a simple diagram chase and usage of $H_2(X^*) \rightarrow H_2(N^*)$ being an isomorphism

- the kernel of i_2 is isomorphic to the kernel of i_1 via the vertical map.
- $H_2((X \setminus \partial Z)^*) \rightarrow H_2((N \setminus Z)^*)$ is surjective, because of the last statement, and because $H_2((N \setminus Z)^*) \rightarrow H_2(N^*)$ is injective.

Thus, $H_3(X \setminus \partial Z) \rightarrow H_3(N \setminus Z)$ is surjective by the same type of argument as when the action is free on N (we only needed $H_2((X \setminus \partial Z)^*) \rightarrow H_2((N \setminus Z)^*)$ to be surjective). In order to conclude the theorem, we have to show that $K_1 \rightarrow K_2$, where

$$K_1 := \ker(H_2(\partial E) \rightarrow H_2(X \setminus \partial Z) \oplus H_2(\partial Z)), \quad K_2 := \ker(H_2(E) \rightarrow H_2(N \setminus Z) \oplus H_2(Z)),$$

is surjective (this suffices by the same proof of the four-lemma about surjectivity, although the assumptions are slightly different). Under the identification $E = Z^* \times S^1 \times T$ we can and we will view $K_2 \subset H_0(Z^*) \otimes H_2(S^1 \times T)$ to be naturally contained in

$$H_0(\partial Z^*) \otimes H_2(S^1 \times T) \subset H_2((\partial E)_1)$$

(see remark 1.1.2 for the notation) from now on. Thus, it suffices to show that

$$K_2 = \ker[H_2((\partial E)_1) \rightarrow H_2(X \setminus \partial Z) \oplus H_2(\partial Z)].$$

In order to understand this, since the occurring maps on spaces are bundle maps, we want to first understand the kernel K'_1 of

$$E_{1,1}^\infty(\partial E) \rightarrow E_{1,1}^\infty(X \setminus \partial Z) \oplus E_{1,1}^\infty(\partial Z).$$

By degree reasons, $E_{1,1}^\infty = E_{1,1}^2$ for all occurring terms. It follows that K'_1 is contained in

$$H_0(\partial Z) \otimes H_1(S^1) \otimes H_1(T),$$

because $\ker(H_1(\partial E^*) \rightarrow H_1(\partial Z^*))$ is contained in $H_0(\partial Z) \otimes H_1(S^1)$ and the map in homology between the fibers is an injection by the discussion just after theorem 2.2.1.

Also, K'_1 is mapped isomorphically (because $\ker(i_1) \rightarrow \ker(i_2)$ is an isomorphism) to the kernel K'_2 of

$$E_{1,1}^\infty(E) \rightarrow E_{1,1}^\infty(N \setminus Z) \oplus E_{1,1}^\infty(Z),$$

which is contained in

$$H_0(Z) \otimes H_1(S^1) \otimes H_1(T),$$

so that we may view both K'_1 and K'_2 to be the same subgroup K' in

$$H_0(\partial Z) \otimes H_1(S^1) \otimes H_1(T) \subset E_{1,1}^\infty(\partial E).$$

Of course, these groups are not necessarily equal to K_1 and K_2 , so we can not conclude the assertion just yet. Using remark 1.1.2, we take a look at the following diagram (whose rows are exact)

$$\begin{array}{ccccccccc}
0 & \longrightarrow & E_{0,2}^\infty(\partial E) & \longrightarrow & H_2((\partial E)_1) & \xrightarrow{j_1} & E_{1,1}^\infty(\partial E) & \longrightarrow & 0 \\
& & \downarrow & & \downarrow & & \downarrow j_2 & & \\
0 & \longrightarrow & E_{0,2}^\infty(\partial Z) \oplus E_{0,2}^\infty(X \setminus \partial Z) & \longrightarrow & G_1 & \longrightarrow & E_{1,1}^\infty(\partial Z) \oplus E_{1,1}^\infty(X \setminus \partial Z) & \longrightarrow & 0 \\
& & \downarrow & & \downarrow & & \downarrow & & \\
0 & \longrightarrow & E_{0,2}^\infty(Z) \oplus E_{0,2}^\infty(N \setminus Z) & \longrightarrow & G_2 & \longrightarrow & E_{1,1}^\infty(Z) \oplus E_{1,1}^\infty(N \setminus Z) & \longrightarrow & 0
\end{array}$$

Here, $G_1 = H_2((\partial Z)_1) \oplus H_2((X \setminus \partial Z)_1)$ and $G_2 = H_2(Z_1) \oplus H_2((N \setminus Z)_1)$ inject into $H_2(\partial Z) \oplus H_2(X \setminus \partial Z)$ resp. $H_2(Z) \oplus H_2(N \setminus Z)$.

Therefore, we want to show that any x in $K_2 \subset H_2((\partial E)_{(1)})$ (which is 0 in G_2 , then) is 0 in G_1 .

We know that $j_1(x) \in K'$, so $j_2(j_1(y)) = 0$. It follows that the image of x in G_1 comes from $E_{0,2}^\infty(\partial Z) \oplus E_{0,2}^\infty(X \setminus \partial Z)$, but this injects into $E_{0,2}^\infty(Z) \oplus E_{0,2}^\infty(N \setminus Z)$ (as argued in the case $Z = \emptyset$). So y is 0 in G_1 , as well, and we have shown the claim and thus the whole assertion. \square

Using section 2.2 and the construction in [GKZ22, Section 3], we get as a corollary:

Theorem 2.2.3. *Any orientable 3-valent GKM graph with $\mathbb{Z}^2 / \pm 1$ -labeling is realizable as a simply-connected GKM manifold over \mathbb{Z} .*

Proof. By [GKZ22, Section 3], there is a T^2 -manifold M whose orbit space is S^4 (so $\pi_1(M) = 0$ by our lemma above) which satisfies all conditions needed in theorem 2.2.1. Smoothness comes from [GKZ22, 3.5], and the other conditions immediately follow from the part [GKZ22, 3.4] of the construction of M . There, equivariant 2-handles $D^2 \times D^2 \times T/H$ (H a finite cyclic subgroup of T , T acting on T/H and on one D^2 -factor) are attached onto the equivariant one-skeleton constructed before, and after that only modifications in the free stratum were made in such a way that the orbit space of M becomes S^4 . \square

Chapter 3

Realization of GKM fibrations

As in the last chapter, this chapter also revolves around the realization problem. However, we will not restrict ourselves to graphs of low valence, but instead focus on a certain subclass of GKM graphs, namely certain GKM fiber bundles. This was already done by Goertsches, Konstantis and Zoller in [GKZ20], where they considered GKM fiber bundles $\Gamma \rightarrow \Gamma' \rightarrow B$, where B is the GKM graph of a quasitoric manifold X of dimension 4, and Γ' is the GKM graph of S^2 . They were not only able to find a GKM manifold M whose GKM graph is Γ' , but also constructed M as the total space of an equivariant fiber bundle $S^2 \rightarrow M \rightarrow X$. Moreover, they showed that, if X is toric, M admits a (not necessarily invariant) Kähler structure, and that M can be chosen to be toric if $\Gamma = \Gamma' \times B$ as unlabeled graphs.

They constructed M as the projectivization of an equivariant \mathbb{C}^2 -bundle over X . This \mathbb{C}^2 -bundle, in turn, was constructed first over the equivariant one-skeleton of X , only to use equivariant obstruction theory to show that this extends to X .

The drawback of this approach using equivariant obstruction theory is that it seems difficult to apply the same technique to GKM fiber bundles $\Gamma' \rightarrow \Gamma \rightarrow B$, where B is now the graph of an arbitrary (quasi)toric manifold, and Γ' is the GKM graph of a generalized flag manifold G/H , where G is a compact, connected semisimple Lie group and H is the centraliser of a subtorus.

Here, we restrict ourselves to the case $H = T$ being a maximal torus of G . The reason for this is that then we can classify all graph automorphisms $\Gamma \rightarrow \Gamma$, allowing us to give a characterization of realizable fiber bundles based on a certain automorphism, which we call the *twist automorphism*. We also construct a big class of examples of 'non-trivial' GKM fiber bundles.

3.1 Graph automorphisms

Similar to the definition of an isomorphism between GKM graphs, we can define an automorphism of a single GKM graph.

Definition 3.1.1. Let $\psi: \Gamma \rightarrow \Gamma$ be a connection preserving automorphism of the unlabeled graph Γ . We call ψ a **graph automorphism** if there exists a linear map $\psi_*: \mathfrak{t}^* \rightarrow \mathfrak{t}^*$ such

that for every edge $e \in \Gamma$ we have $\psi_*(\alpha(e)) = \alpha(\psi(e))$.

Let $\Gamma \rightarrow \Gamma' \rightarrow B$ be a GKM fiber bundle, where B is a two-valent GKM-graph and Γ the GKM graph of G/T as described in theorem 1.2.25 and the discussion thereafter, endowed with its canonical connection. We assume now and throughout that any two weights at some vertex (and hence any vertex) of B , which are elements in the weight lattice of T , span a primitive lattice in the latter. We label the n vertices of B by $v_1, \dots, v_n, v_{n+1} = v_1$, and assume without loss of generality that Γ is the fiber over v_1 . Now, we obtain a graph automorphism $\psi: \Gamma \rightarrow \Gamma$ by $\Psi_{(v_n, v_1)} \circ \dots \circ \Psi_{(v_1, v_2)}$, see definition 1.2.28.

We give basic examples of graph automorphisms induced by maps from G/T to itself.

Example 3.1.2. Clearly, G -equivariant diffeomorphisms from G/T to itself also define T -equivariant ones. The former are in one to one correspondence with $N_G(T)/T$, where this correspondence is given by sending a diffeomorphism f to its value w on eT , or, the other way around, sending w onto the map $gT \mapsto gwT$, that is, right-multiplication with w . Therefore, such f induces a graph automorphism $\psi: \Gamma \rightarrow \Gamma$ in the following way:

- A vertex $[w']$ is sent to the vertex $[w'w]$, where we consider w as an element in $W(G)$.
- An edge e between $[w']$ and $[w'\sigma_\alpha]$ is sent to the edge between $[w'w]$ and $[w'\sigma_\alpha w]$.
- Since the diffeomorphism is T -equivariant, ψ_* sends α to α .

Example 3.1.3. We can also consider left-multiplication with elements in $N_G(T)$, $f(gT) = wgT$. We have the equation $f(tgT) = wtgT = wtw^{-1}wgt = c_w(t)f(gT)$, so f is not equivariant, but rather twisted equivariant with respect to c_w . Thus, it induces a graph automorphism via $\psi_*(\alpha) := \alpha \circ \text{Ad}(w)^{-1} = \text{Ad}(w)^*(\alpha)$.

There is one more natural example coming from certain automorphisms of G .

Example 3.1.4. For an automorphism $\psi: G \rightarrow G$ sending T to itself, there is an induced diffeomorphism $\psi: G/T \rightarrow G/T$. The graph automorphism is induced in a natural way by the maps $\psi: W(G) \rightarrow W(G)$ and $\psi_*: \mathfrak{t}^* \rightarrow \mathfrak{t}^*$ (i.e., the Lie algebra automorphism). As $\psi: W(G) \rightarrow W(G)$ is a homomorphism, at least $e \in W(G)$ is fixed and so its corresponding vertex.

Definition 3.1.5. We say that the automorphisms in 3.1.3 are of **Type 1** and that those in 3.1.4 are of **Type 2**.

Remark 3.1.1. At first glance, it might seem odd that right-multiplication featured in 3.1.2 is not relevant to us here. However, since multiplication with $w \in N_G(T)$ from the right can be written as composition of left-multiplication with w (which is of Type 1) and conjugation with w^{-1} (which is of Type 2), right-multiplication is already covered by 3.1.3 and 3.1.4.

The main part of this section is the statement that all graph automorphisms come from the examples mentioned before. But first, we need two lemmata, the last of which is standard and proven for completeness.

Lemma 3.1.2. Any graph automorphism ψ is uniquely determined by its value on one vertex v and all edges emerging from it.

Proof. It is clear that the linear map $\psi_*: \mathfrak{t}^* \rightarrow \mathfrak{t}^*$ is uniquely determined, as the labels on the edges at a vertex span \mathfrak{t}^* . So this is a statement purely on graph level.

Let v' be a vertex connected by the edge e to v . By definition, ψ maps v' to the vertex $\psi(v')$ connected by $\psi(e)$ to $\psi(v)$. Let $e' \neq e$ be another edge emerging from v' . We may write it as $\nabla_e \hat{e}$, where \hat{e} is some edge emerging from v . Since ψ preserves ∇ , the edge $\psi(e')$ is determined by $\psi(e)$ and $\psi(\hat{e})$. Since Γ was assumed to be connected, we are done. \square

Lemma 3.1.3. Let \mathfrak{g} be the Lie algebra of a compact semisimple Lie group, \mathfrak{t} a maximal abelian subalgebra and $\phi: \mathfrak{t}^* \rightarrow \mathfrak{t}^*$ a linear automorphism permuting the roots of \mathfrak{g} . Assume, moreover, that ϕ respects the Cartan integers. Then ϕ extends to an automorphism of \mathfrak{g} .

Proof. We start by complexifying everything to obtain an automorphism $\phi_{\mathbb{C}}$ of the root system of $\mathfrak{g}_{\mathbb{C}}$. Let $(\alpha_1, \dots, \alpha_n)$ be a basis for the root system, (h_1, \dots, h_n) a corresponding real basis for $\mathfrak{t}_{\mathbb{C}}$, and $(\alpha'_1, \dots, \alpha'_n)$ and (h'_1, \dots, h'_n) their respective images under $\phi_{\mathbb{C}}$. Let $X_i \in \mathfrak{g}_{\alpha_i}$ be an element such that $[h_i, X_i] = 2X_i$, $[h_i, \bar{X}_i] = -2\bar{X}_i$ and $[X_i, \bar{X}_i] = h_i$, and choose the X'_i in the same way. By a theorem of Serre, $\mathfrak{g}_{\mathbb{C}}$ is generated as a Lie algebra by the h_i , the X_i and the \bar{X}_i subject to relations that are left invariant under the transformation $h_i \rightarrow h'_i$, $X_i \rightarrow X'_i$ and $\bar{X}_i \rightarrow \bar{X}'_i$. Thus, we get a well defined automorphism of $\mathfrak{g}_{\mathbb{C}}$ which commutes with complex conjugation and therefore leaves $\mathfrak{g} = \mathfrak{g}_{\mathbb{R}} \subset \mathfrak{g}_{\mathbb{C}}$ invariant. This proves the claim. \square

In the next lemma, we link the length of a connection path $P_{\alpha, \beta}$ of G/T (with respect to the canonical connection) generated by two edges at $[e]$ corresponding to two roots α and β to the Cartan integer of those roots. Denote by $\text{ord}(g)$ the order of an element g in a finite group.

Lemma 3.1.4. We have $\#E(P_{\alpha, \beta}) = 2\text{ord}(s_{\alpha}s_{\beta})$. In particular, the Cartan integer of α and β is uniquely determined by $\#E(P_{\alpha, \beta})$.

Proof. We are free to switch between considering s_{α} and s_{β} as reflections in \mathfrak{t}^* or elements in $W(G)$. If s_{α} and s_{β} do not commute (if they do, the path clearly has four edges), the connection path $P_{\alpha, \beta}$ looks as follows.

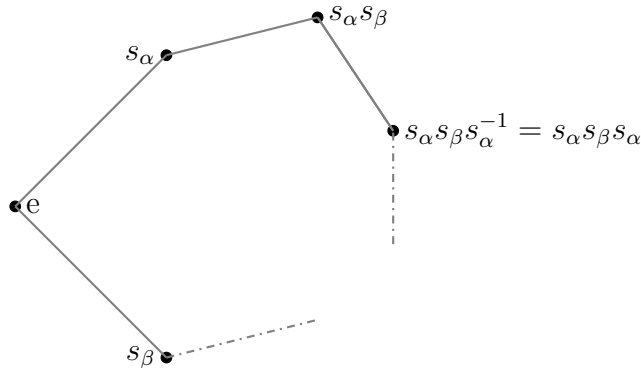

The dotted lines indicate that the path continues. This path closes the first time as soon as $(s_\alpha s_\beta)^k = \text{id}_{\mathfrak{t}^*}$ or $(s_\alpha s_\beta)^k s_\alpha = \text{id}_{\mathfrak{t}^*}$. The latter case is impossible, since the left hand side has determinant -1 . In the first case, we clearly have $2k$ edges in the loop.

The last statement about the Cartan integers now follows from standard Lie theory. \square

Theorem 3.1.6. *Let $\psi: \Gamma \rightarrow \Gamma$ be a graph automorphism. Then there are graph automorphisms ψ_1 and ψ_2 of Type 1 and 2, respectively, such that $\psi = \psi_1 \circ \psi_2$.*

Proof. Let v be the vertex corresponding to $e \in W(G)$. We define ψ_1 to be the graph automorphism sending v to $\psi(v)$, i.e. ψ_1 is left multiplication with an element in $N_G(T)$ descending to $\psi(v) \in W(G)$. Then $\psi_2 := (\psi_1)^{-1} \circ \psi$ sends v to itself and we only need to check that it is of Type 2, i.e. it comes from an automorphism of G .

Indeed, ψ_2 permutes all the edges emerging from v and has the property $\alpha(\psi_2(e)) = (\psi_2)_*(\alpha(e))$, implying that $(\psi_2)_*$ is an isomorphism of \mathfrak{t}^* permuting the roots. Since ψ_2 preserves the connection, $(\psi_2)_*$ preserves the Cartan integers by 3.1.4. Theorem 3.1.3 delivers us an automorphism of \mathfrak{g} inducing $(\psi_2)_*$. As G was assumed to be simply-connected, this automorphism of \mathfrak{g} is induced by an automorphism ϕ of G . The graph automorphism induced by ϕ agrees with ψ_2 on v and all edges emerging from it. In view of 3.1.2, this shows the assertion. \square

3.2 Examples of GKM fiber bundles

Now we want to give many examples of GKM fiber bundles $\Gamma \rightarrow \Gamma' \rightarrow B$ as described at the start of this chapter whose twist automorphism is of **Type 1** (3.1.3). It will become apparent in 3.3 why we focus on these.

At first, we note that if a GKM fiber bundle is given and its twist automorphism is determined by $w \in W(G)$, then for any weight α of the fiber graph, the difference $\text{Ad}(w)^*(\alpha) - \alpha$ needs to be contained in the two-dimensional subspace of \mathfrak{t}^* spanned by the weights of the base graph. Thus, $\text{Ad}(w)$ has to fix a subspace of \mathfrak{t} of codimension 2, or equivalently (by our assumptions on the labeling of B), there is a subtorus $T' \subset T$ of codimension 2 which is fixed by c_w .

The other way around, given some $w \in W(G)$ such that c_w fixes a subtorus $T' \subset T$ of codimension 2, we can choose a basis (α, β) of $\text{ann}(\text{Lie}(T'))$ and get a graph B of any toric manifold such that the weights are linear combinations of α and β . Having fixed w , T' and B , we ask ourselves how to construct signed GKM fiber bundles $\Gamma \rightarrow \Gamma' \rightarrow B$ up to automorphisms of T (that is, we assume that the labels of a fiber graph over a base vertex v_1 are fixed). We label the n vertices of B by $v_1, v_2, \dots, v_n, v_{n+1} = v_1$, denote by α_i the signed weight of the edge (v_i, v_{i+1}) , by T_i its kernel and by ψ_i an automorphism of T that fixes T_i and is orientation preserving. Now if we want to construct $\Gamma \rightarrow \Gamma' \rightarrow B$, we already know how the pure graph has to look like, so we only need to care about the labeling.

We start over the edge (v_1, v_2) . It is clear that there are as many such GKM fiber bundles $\Gamma \rightarrow \Gamma'_{(v_1, v_2)} \rightarrow (v_1, v_2)$ as there are choices of ψ_1 . Now there are as many choices to extend

this bundle to $(v_1, v_2) \cup (v_2, v_3)$ as there are choices for ψ_2 , and so on. We can go on like this until we need to consider ψ_n . In principle, ψ_n could be chosen arbitrary, but we have already chosen the ψ_i , $i \in \{1, \dots, n-1\}$, and we need the condition $\psi_n \circ \dots \circ \psi_1 = \text{Ad}(w)$ to be satisfied.

Any ψ_i can be seen as an element in $\text{SL}(m, \mathbb{Z})$ which fixes $\text{Lie}(T')$. We choose a basis w_1, \dots, w_{m-2} for the canonical lattice of the latter, given by the kernel of the exponential map, and extend this to a basis w_1, \dots, w_m for the lattice of $\text{Lie}(T)$ such that w_{m-1} is fixed by ψ_{n-1} and w_m is fixed by ψ_n (this is possible by [GHV73, p. 57, Exercise 7]). With respect to this basis, any ψ_i is of the form

$$\begin{pmatrix} 1_{\mathbb{Z}^{m-2}} & B_i \\ 0 & A_i \end{pmatrix}$$

where B_i is some $(m-2) \times 2$ -matrix and A_i is in $\text{SL}(2, \mathbb{Z})$, such that the combined $m \times 2$ -matrix fixes the kernel of α_i . Note that this condition for $i = n-1$ and $i = n$ forces A_{n-1} and A_n to be of the form

$$A_{n-1} = \begin{pmatrix} 1 & * \\ 0 & 1 \end{pmatrix}, \quad A_n = \begin{pmatrix} 1 & 0 \\ * & 1 \end{pmatrix}$$

Of course, $\text{Ad}(w)$ has the same form as the ψ_i , but without the restriction on A_w and B_w . Now we can formulate and prove the following theorem.

Theorem 3.2.1. *For the basis (w_1, \dots, w_m) from above, any choice of the above A_1, \dots, A_n such that $A_n \cdot \dots \cdot A_1 = A_w$ and for any choice of the above B_1, \dots, B_{n-2} , there are unique B_{n-1} and B_n such that $\psi_n \cdot \dots \cdot \psi_1 = \text{Ad}(w)$. So for $m \geq 3$, any choice of the labeling of the fiber graph over v_1 such that no weights are contained in the real span of the base weights yields a GKM fiber bundle.*

Proof. We set $\psi = \text{Ad}(w) \cdot \psi_1^{-1} \cdot \dots \cdot \psi_{n-2}^{-1}$. This is of the form

$$\psi = \begin{pmatrix} 1_{\mathbb{Z}^{m-2}} & B \\ 0 & A_n \cdot A_{n-1} \end{pmatrix}.$$

Here, B is of the form (u_1, u_2) , where u_1 and u_2 are column vectors of length $m-2$. Remember that A_{n-1} and A_n are given by

$$A_{n-1} = \begin{pmatrix} 1 & k_1 \\ 0 & 1 \end{pmatrix}, \quad A_n = \begin{pmatrix} 1 & 0 \\ k_2 & 1 \end{pmatrix}.$$

for certain integers k_1 and k_2 . Moreover, the left entries of B_{n-1} as well as the right entries of B_n have to be 0, because the combined $m \times 2$ -matrix of B_{n-1} and A_{n-1} , for example, has to fix w_{m-1} , so we have matrices of the form

$$\psi_n = \begin{pmatrix} 1_{\mathbb{Z}^{m-2}} & (u'_1, 0) \\ 0 & A_n \end{pmatrix}, \quad \psi_{n-1} = \begin{pmatrix} 1_{\mathbb{Z}^{m-2}} & (0, u'_2) \\ 0 & A_{n-1} \end{pmatrix}.$$

Their product $\psi_n \cdot \psi_{n-1}$ now is

$$\psi_n \cdot \psi_{n-1} = \begin{pmatrix} 1_{\mathbb{Z}^{m-2}} & (u'_1, u'_2 + k_1 u'_1) \\ 0 & A_n \cdot A_{n-1} \end{pmatrix}$$

Thus, we only have the choices $u'_1 = u_1$ and $u'_2 = u_2 - k_1 u_1$ and have found a labeling. If the labeling of the fiber over v_1 is as proposed in the lemma, then it is clear that the same holds for v_2, v_3 and so on, meaning that the labeled graph Γ' is indeed a GKM graph. \square

Remark 3.2.2. Above, we started with the base weights and then assumed the existence of a certain labeling of Γ_{v_1} . Of course, this is equivalent to starting with the labeling of Γ_{v_1} and then giving the base weights, as long as we assume that the lattice spanned by these is primitive in the weight lattice of T^m , because there is always an element of $\mathrm{SL}(m, \mathbb{Z})$ sending a primitive lattice of rank r to any other one.

Given a labeling of Γ' with weights $\alpha_1, \dots, \alpha_j$ for $m \geq 3$, we can find many weights β_1 and β_2 such that the lattice spanned by the latter is primitive and contains no element α_i . This directly follows from the following considerations: given non-zero elements v_1, \dots, v_j in \mathbb{Z}^m , we can always find elements β'_1 and β'_2 in \mathbb{Q}^n such that the rational 2-plane E spanned by the latter contains none of the v_j . Now $E \cap \mathbb{Z}^m$ is of rank 2, non-empty and primitive in the sense that any element primitive in E is primitive in \mathbb{Z}^m , which is equivalent to \mathbb{Z}^m/E being free abelian. Now choose an integer basis β_1 and β_2 of E that give the basis weights at v_1 .

We can thus find examples of such GKM fiber bundles by finding these A_i in theorem 3.2.1. It seems hard to classify all such solutions, but nonetheless we can find many for an arbitrary toric base, except $\mathbb{C}P^2$, and lots of Lie groups G .

Example 3.2.3. Let B be the yet unlabeled graph of a Hirzebruch surface. Suppose there is an embedded $\mathfrak{su}(3) \subset \mathrm{Lie}(G)$. This is fixed by the adjoint representation of a subtorus $T' \subset T$ of codimension 2. We set $e_1 = 2\pi i \mathrm{diag}(1, -1, 0)$, $e_2 = 2\pi i \mathrm{diag}(0, 1, -1)$ and $e_3 = 2\pi i \mathrm{diag}(1, 0, -1)$. For some $b \in \mathbb{Z}$, we choose the basis $w_{m-1} = be_1 + e_2$ and $w_m = (b-1)e_1 + e_2$ for the canonical lattice of the maximal torus in $\mathfrak{su}(3)$, and a basis w_1, \dots, w_{m-2} for the canonical lattice of $\mathrm{Lie}(T')$. We denote by w the Weyl group element of G whose action on T' is trivial and which sends e_1 resp. e_2 to $-e_3$ resp. e_1 (in the usual identification of $W(\mathfrak{su}(3))$ with S_3 , this is the element $(23) \circ (12)$). The matrix of this isomorphism with respect to the basis w_{m-1} and w_m is now

$$\mathrm{Ad}(w) = \begin{pmatrix} b & b-1 \\ 1 & 1 \end{pmatrix} \begin{pmatrix} -1 & 1 \\ -1 & 0 \end{pmatrix} \begin{pmatrix} 1 & -b+1 \\ -1 & b \end{pmatrix} = \begin{pmatrix} -3b+1 & * \\ -3 & * \end{pmatrix}$$

Now we want the edge (v_2, v_1) of B to have label dual to w_m , (v_2, v_3) to have label dual to w_{m-1} and (v_3, v_4) to have label dual to w_m again. We set A_4 to be the identity and have

$$A_3^{-1} \begin{pmatrix} -3b+1 & * \\ -3 & * \end{pmatrix} := \begin{pmatrix} 1 & -b \\ 0 & 1 \end{pmatrix} \begin{pmatrix} -3b+1 & * \\ -3 & * \end{pmatrix} = \begin{pmatrix} 1 & k_1 \\ -3 & -3k_1+1 \end{pmatrix}$$

for a certain integer k_1 . Thus,

$$\begin{pmatrix} 1 & b \\ 0 & 1 \end{pmatrix} \begin{pmatrix} 1 & 0 \\ -3 & 1 \end{pmatrix} \begin{pmatrix} 1 & k_1 \\ 0 & 1 \end{pmatrix} = \text{Ad}(w)$$

By theorem 3.2.1, we obtain many GKM fiber bundles whose twist automorphism is $\text{Ad}(w)$ and whose base B is the graph of a Hirzebruch surface.

Now it is well known that every toric manifold of dimension 4 except $\mathbb{C}P^2$ is obtained by a sequence of blow-ups of a Hirzebruch surface H (see [YK99, Lemma 6.8], for example). This gives a GKM fiber bundle for every such base, because we take the GKM fiber bundle we just constructed for H and set ψ_i to be the identity for a newly emerging edge after one single blow-up.

3.3 The construction

Now we want to construct the geometric realizations of all feasible GKM fiber bundles.

Theorem 3.3.1. *Let Γ' be the total space of a GKM fiber bundle $\Gamma \rightarrow \Gamma' \rightarrow B$, where Γ is the GKM graph of G/T endowed with its canonical connection, and B is the graph of a quasitoric manifold X . Denote by $\psi = \psi_1 \circ \psi_2$ the twist automorphism of this bundle. There is a geometric realization $G/T \rightarrow M \rightarrow X$ of $\Gamma \rightarrow \Gamma' \rightarrow B$ if ψ is given by left-multiplication with an element $w \in N_G(T)$.*

Proof. We label the vertices of the base graph B by $\dots, v_n = v_0, v_1, \dots, v_n, v_{n+1} = v_1, \dots$, and we assume $n \geq 2$. Without loss of generality we may assume that the fiber graph over v_1 is the graph associated to the G -manifold G/T , that is, the T -action on G/T comes from the group structure on G by left-multiplication. We call this T -manifold F_1 . By preapplying the torus automorphism $\Psi_{(v_1, v_2)}$, we change the T -action on F_1 , giving us another copy F_2 of G/T where T now acts according to the labels of Γ_{v_2} . We iterate this process to define F_3, \dots, F_n . Similarly, we write G_1 for the group G considered as a T -manifold (acting as left-multiplication), and then by G_2 the T -action obtained by preapplying $\Psi_{(v_1, v_2)}$, and iterate this to obtain G_3, \dots, G_n . Also, we denote by ψ the geometric realization of the graph automorphism.

In particular, there are T -equivariant maps $f_k: S^1 \times G_k \rightarrow G_{k+1}$ (where the kernel of the T -action on S^1 is determined the weight on the edge (v_k, v_{k+1})) defined by demanding that f_k restricted to $\{e\} \times G_k$ is the identity and extending this equivariantly. This is well-defined, since when $t \in T$ fixes S^1 , then the actions of T on G_k respectively G_{k+1} agree by the compatibility condition of a GKM fiber bundle.

We also define G_{n+1} , F_{n+1} and $f_n: S^1 \times G_n \rightarrow G_{n+1}$ in a similar way. Then, the T -spaces G_1 and G_{n+1} (and thus F_1 and F_{n+1}) are equivariantly diffeomorphic, via the geometric realization $\psi: G_1 \rightarrow G_{n+1}$. In what follows, we construct a T -equivariant, principal G -bundle (G acting from the right), which allows us to pass to the desired G/T -bundle.

Let D_i be 4-disks (with boundary) with T -action corresponding to the weights at v_i (choose signs, if necessary), and fix equivariant embeddings $: D_i \rightarrow X$ sending 0 to the fixpoint p_i corresponding to v_i , for $i \in \{1, \dots, n\}$, such that the images of the interiors of D_i and D_{i+1} intersect in a small neighborhood of a T^2 -orbit in the two-sphere corresponding to the edge (v_i, v_{i+1}) . Denote by $U_i^\pm \subset D_i$ a small neighborhood of the isotropy subcircle N_i^\pm corresponding to the edge $(v_i, v_{i\pm 1})$. This induces equivariant diffeomorphisms $h_i: U_i^+ \rightarrow U_{i+1}^-$.

Now consider the T -manifolds $(D_i \setminus N_i^+) \times G_i$ and $(D_{i+1} \setminus N_{i+1}^-) \times G_{i+1}$. We can glue them along $U_i^+ \times G_i$ and $U_{i+1}^- \times G_{i+1}$ using the equivariant diffeomorphism

$$\tilde{f}_i: U_i^+ \times G_i \rightarrow U_{i+1}^- \times G_{i+1}, \quad (s, z_1, z_2, p) \mapsto (h_i(s, z_1, z_2), f_i(z_1, p)).$$

This still has a natural structure of a T -equivariant, principal G -bundle. We can iterate this process and attach $(D_3 \setminus N_3^-) \times G_3$, $(D_4 \setminus N_4^-) \times G_4, \dots$ up until $D_n \times G_n$. Then, we remove $N_1^- \times G_1$ and $N_n^+ \times G_n$ out of this space and identify $U_1^- \times G_1$ and $U_n^+ \times G_n$ via

$$U_n^+ \times G_n \xrightarrow{\tilde{f}_n} U_1^- \times G_{n+1} \xrightarrow{\text{id} \times \psi^{-1}} U_1^- \times G_1.$$

The resulting manifold with boundary is the total space of a T -equivariant G -bundle whose base X' is a neighborhood of the equivariant one-skeleton of X , which is equivariantly diffeomorphic to X minus an open neighborhood of a free T^2 -orbit. Moreover, we still have the right-action of G , because ψ is given by left-multiplication with w . In order to get the bundle over whole X , we need to show that it is trivial over the boundary $\partial X' = S^1 \times T^2$, and that this trivialization is also G -equivariant with respect to the right-action of G .

By the construction of the bundle over X' , the bundle over $\partial X'$ is obtained by gluing chunks of the form $[0, 1] \times T^2 \times G_i$ and $[0, 1] \times T^2 \times G_{i+1}$ together along their respective boundaries by demanding that the gluing map is equivariant with respect to T , and the identity on $\{e\} \times G_i$ for $i \in \{1, \dots, n-1\}$ respectively ψ^{-1} on $\{e\} \times G_n$. Thus, the bundle over $S^1 \times T^2$ is both T -equivariantly and G -equivariantly isomorphic to the bundle $[0, 1] \times T^2 \times G_1 / \sim_\phi$, where ϕ is given by $(e, p) \mapsto (e, \psi^{-1}(p))$ and T -equivariant extension.

Now if ψ is given by left-multiplication with w , the equivariance of ψ with respect to T' , the kernel of the T -action on X , reads

$$t \cdot wg = wtg,$$

which is true if and only if w is in the centralizer of T' . Since the latter is path-connected, there is a path from w to $\{e\}$ through elements centralizing T' , which means that there is indeed an isomorphism to $S^1 \times T^2 \times G_1$ which is compatible with both the T -action and the G -action. This enables us to extend the bundle over X' to whole X equivariantly, and we are done. \square

Remark 3.3.1. It is important to note that one could also consider GKM fiber bundles $\Gamma \rightarrow \Gamma' \rightarrow B$, where Γ is not endowed with its canonical connection (in principle, there could

be many). It is unclear to the authors whether loosening this restriction that Γ is supposed to be endowed with its canonical connection gives rise to more examples.

Remark 3.3.2. Of course, we can always construct a bundle $G/T \rightarrow M_{(1)} \rightarrow X_1$ over the equivariant one-skeleton $X_1 \subset X$ associated to $\Gamma \rightarrow \Gamma' \rightarrow B$ with the method as in the last proof, regardless of what ψ is. For any vertex v_i in B , any edge e' in Γ_{v_i} and any horizontal edge e at v_i , the T -invariant spheres corresponding to e' and $\nabla_e e'$ are homotopic by our construction.

We want to show in the following that the bundle is not realizable if ψ_2 is not the identity on Γ . We need a small lemma, first.

Lemma 3.3.3. Let $\psi': G \rightarrow G$ be an automorphism that sends T to itself. Denote by ψ the induced self-diffeomorphism $G/T \rightarrow G/T$. Then $\psi^*: H^2(G/T) \rightarrow H^2(G/T)$ is the identity if and only if ψ' restricted to T is the identity.

Proof. We have two T -actions on G now: the one given by the prescribed embedding of T , whose fundamental vector fields we denote by \overline{X} , and the one twisted with ψ , whose fundamental vector fields we denote by \widetilde{X} . We denote by G the manifold G with the first T -action and by G' the manifold G with the twisted T -action.

We use the Cartan models (see [GZ19], for example) of G resp. G' to see this. We denote the equivariant differentials by D resp. D' . There is the well-known isomorphism $H^2(G/T) \cong \mathfrak{t}^*$, coming from the injection $\mathfrak{t}^* \rightarrow \mathfrak{t}^* \otimes \Omega^0(G) \subset S(\mathfrak{t}^*) \otimes \Omega^T(G)$ ([GZ19, Theorem 10.3]). The automorphism ψ' induces an isomorphism $d\psi' = g: \mathfrak{t} \rightarrow \mathfrak{t}$ and thus an isomorphism $f: \mathfrak{t}^* \rightarrow \mathfrak{t}^*$ by $f(\alpha) = \alpha \circ g$, and thus an chain isomorphism between the Cartan models by $f \otimes \psi'^*$, because

$$[(f \otimes \psi'^*)(D'\omega)](X) = \psi'^*(D\omega(g(X))) = d\psi'^*(\omega(g(X))) - \psi'^*(i_{\widetilde{X}}\omega(g(X)))$$

and also, because $\psi'_*(\overline{X}) = \widetilde{X}$,

$$D((f \otimes \psi'^*)(\omega))(X) = d\psi'^*(\omega(g(X))) - i_{\overline{X}}(\psi'^*\omega(g(X))) = d\psi'^*(\omega(g(X))) - \psi'^*(i_{\widetilde{X}}\omega(g(X)))$$

and thus an isomorphism between equivariant cohomologies. We thus get the following commutative diagram:

$$\begin{array}{ccccc} \mathfrak{t}^* & \xrightarrow{\cong} & H_T^2(G') & \xrightarrow{\cong} & H^2(G'/T) \\ \downarrow f & & \downarrow f \otimes \psi'^* & & \downarrow \psi^* \\ \mathfrak{t}^* & \xrightarrow{\cong} & H_T^2(G) & \xrightarrow{\cong} & H^2(G/T) \end{array}$$

This shows the claim. □

Lemma 3.3.4. The bundle $\Gamma \rightarrow \Gamma' \rightarrow B$ corresponding to $\psi = \psi_1 \circ \psi_2$ is not realizable as $G/T \rightarrow M \rightarrow X$, where we mean by G/T any T -action on G/T with graph Γ , if $\psi_2 \neq \text{id}_\Gamma$.

Proof. We denote by w the element of $N_G(T)$ that induces ψ_1 , by $\phi_2: G/T \rightarrow G/T$ an automorphism that induces ψ_2 and by ϕ the composition $w \cdot \phi_2$. We will show that, if the bundle is realizable as $G/H \rightarrow M \rightarrow X$, then the lift of ϕ_2 to G is necessarily the identity on T , which would imply that $\psi_2 = \text{id}_T$.

Since multiplication with w induces the identity on $H_2(G/T)$ (we always take homology with \mathbb{R} -coefficients in this proof), we have $\phi_* = (\phi_2)_*$. Therefore, it suffices to show that ϕ_* is the identity on $H_2(G/T)$ by lemma 3.3.3.

To do this, we want to show that the monodromy $\pi_1(X_1) = \pi_1(S^1) \rightarrow \text{Aut}(H_2(G/T))$ is generated by ψ_* , just as for the special construction in 3.3.2. Choose an edge e_1 in $\Gamma_{v'_1}$, where v'_1 is a vertex of B , and some vertex of e_1 called v_1 and denote by S_1 the corresponding T -invariant sphere in F_1 . We define v_i in Γ to be the end of a lift of the edge path $(v'_1, v'_2), (v'_2, v'_3), \dots, (v'_{i-1}, v'_i)$ that starts in v_1 . Having defined e_{i-1} , we define e_i as $e_i := \nabla_{(v_{i-1}, v_i)} e_{i-1}$ and correspondingly denote by S_i the sphere in F_i (we do this for $i = n+1$, as well).

Choose a subcircle that does not fix any S_i , and choose an orientation on S_i by taking the fundamental vector field of a generator Y of the Lie algebra of this circle and a radial vector at the fixpoint corresponding to v_i . We claim that the fundamental classes of $S(e_i)$ and $S(e_{i+1})$ with this orientation define the same element in the total space E of the bundle restricted to the sphere $S((v_i, v_{i+1})) \subset X_1$. Since the maps $H_2(S(e_i)) \rightarrow H_2(E)$ are completely encoded in the graph of E (the map in cohomology as, and this determines the corresponding map in homology), it suffices to check this for any GKM-manifold with the same graph. For this we can take the bundle as in 3.3.2 and restrict it to $S((v_i, v_{i+1}))$, because there, S_i and S_{i+1} are homotopic with this orientation.

This also shows that for any path $\gamma_{1,2}$ from the fixpoint p_i of $S((v_i, v_{i+1}))$ to the other fixpoint p_{i+1} and any map $g^i: S^2 \rightarrow F_i$ such that $g^i_*[S^2] = [S_i]$, any lift f^i of $S^2 \times [0, 1] \xrightarrow{\pi_2} [0, 1] \xrightarrow{\gamma_{1,2}} S((v_i, v_{i+1}))$ to $M_{(1)}$ with $f^i(\cdot, 0) = g^i$ has the property that $f^i(\cdot, 1)_*([S_i]) = [S_{i+1}]$.

This holds for both our given bundle and the special bundle constructed in 3.3.2. So, for both bundles, consider a generator $\gamma = \gamma_{n,n+1} \cdot \dots \cdot \gamma_{1,2}$ of $\pi_1(X_1)$. By composing the f^i , we see that any lift f of

$$S^2 \times [0, 1] \xrightarrow{\pi_2} [0, 1] \xrightarrow{\gamma} X_1$$

to $M_{(1)}$ with $f(\cdot, 0) = g^1$ has the property that $f(\cdot, 1)_*([S_1]) = [S_{n+1}]$. We want to show that for any T -action on G/T whose GKM graph agrees with the graph of the standard T -action there is an isomorphism between the respective second homology groups that respects both the classes $[S_1]$ and $[S_{n+1}]$, because then the monodromies for both our bundles are the same. We certainly have an isomorphism between the second cohomology groups coming from the isomorphism between cohomology of the manifold and graph cohomology. By dualizing, we get an isomorphism g of the second homology groups, and this will do the job. To see this, we choose signs at the labels of $e_1 = (v_1, w_1)$ and $e_{n+1} = (v_{n+1}, w_{n+1})$ in such a way that the evaluation Lie algebra element Y chosen before is positive. Now, any $\omega \in H^2(M)$ can be

described by $\omega \in H_T^2(\Gamma)$, where

$$H_T^2(\Gamma) = \left\{ \omega \in \bigoplus_{v \in V(\Gamma)} H^2(BT): \omega_v - \omega_{v'} \equiv 0 \pmod{\alpha(e)} \text{ for all edges } e \text{ between } v, v' \right\}.$$

With this description, we have (remember that we chose signs for the labels!)

$$\omega([S_1]) = 2\pi(\omega_{w_1} - \omega_{v_1})/\alpha(e_1), \quad \omega([S_{n+1}]) = 2\pi(\omega_{w_{n+1}} - \omega_{v_{n+1}})/\alpha(e_{n+1}),$$

for both the standard action and any action, because this holds for any effective T -action on a 2-sphere (use equivariant deRham cohomology, for example, and the ABBV-localization formula). This shows that in the general case, too, the monodromies for both our bundles evaluated on $\mathbb{R} \cdot [S_1]$ agree.

But $H_2(G/T)$ is generated by T -invariant spheres and S_1 was arbitrary, so they agree on $H_2(G/T)$. Since the monodromy of the one in 3.3.2 is generated by ψ_* , both are, and so the injectivity of $H_*(G/T) \rightarrow H_*(M)$ (the spectral sequence associated to $G/T \rightarrow M \rightarrow X$ collapses by degree reasons) implies that ψ_* is the identity on $H_2(G/T)$ as claimed. \square

Chapter 4

Multiplicity free $U(2)$ -manifolds and triangles

A fundamental invariant of a compact and connected Hamiltonian K -manifold M , where K is a compact connected Lie group, is its momentum polytope $\mathcal{P}(M)$. In [Kno11], F. Knop showed that if M is *multiplicity free* (cf. definition 1.3.6 below) then $\mathcal{P}(M)$ together with the principal isotropy group of the K -action uniquely determines M . This assertion had been conjectured by Th. Delzant in the 1990s, after proving it for abelian K in [Del88] and for K of rank 2 in [Del90]. Knop also gave necessary and sufficient conditions for a polytope to be the momentum polytope of such a multiplicity free manifold M . These conditions involve a representation theoretic object, called *weight monoid*, associated to smooth affine spherical varieties, which constitute a certain class of complex algebraic varieties equipped with an action of a complex reductive group.

Here, we apply Knop’s classification result in the case where $K = U(2)$ and determine the compact and connected multiplicity free Hamiltonian $U(2)$ -manifolds whose momentum polytope is a triangle and whose principal isotropy group is trivial. The result is summarized in table 4.2. In contrast to Knop’s work, which yields local descriptions of the multiplicity free manifold “above” open subsets of the momentum polytope, we have found explicit, global descriptions of the $U(2)$ -manifolds under consideration. Our hope is that they constitute useful “experimental data” to study the following natural question: Which geometric information about a multiplicity free manifold M can “directly” be read off its momentum polytope $\mathcal{P}(M)$?

The first purpose of section 4.1 is to further specialize Knop’s theorem 1.3.9 to the case $K = U(2)$: the classification of smooth affine spherical $(SL(2, \mathbb{C}) \times \mathbb{C}^\times)$ -varieties from [PPVS18] yields proposition 4.1.3, which gives an elementary and explicit characterization of the momentum polytopes of compact and connected multiplicity free $U(2)$ -manifolds with trivial principal isotropy group. A first application is proposition 4.1.7, which extends the applicability of the Kählerizability criterion [Woo98b, Theorem 8.8] due to C. Woodward. We also extend [Woo98b, Theorem 9.1] and show in proposition 4.1.17, using the extension criterion of S. Tolman’s [Tol98], that a multiplicity free $U(2)$ -manifold with trivial principal

isotropy group carries a $U(2)$ -invariant compatible complex structure if and only if it carries a T -invariant compatible complex structure, where T is a maximal torus of $U(2)$. We then apply proposition 4.1.3 to find the list of all triangles which occur as momentum polytopes of such manifolds in proposition 4.2.2. The rest of section 4.2 is devoted to the proof of theorem 4.2.3: for each such triangle we explicitly and globally describe the corresponding compact and connected multiplicity free $U(2)$ -manifold. Finally, in theorem 4.3.3 of section 4.3, we show that exactly four nonequivariant diffeomorphism types occur among these manifolds.

We have tried to keep the exposition explicit and elementary in order to make our results and the employed techniques, which come from different areas of mathematics, accessible to as many readers as possible. The techniques can directly be applied to the other compact Lie groups of rank 2 and should yield analogous classifications and results.

Notation

We use the convention that $0 \in \mathbb{N}$. From section 4.1 onwards, T will be the maximal torus of $U(2)$ consisting of diagonal matrices and $T^{\mathbb{C}}$ the subgroup of diagonal matrices in $GL(2) := GL(2, \mathbb{C})$. We will use the notation from example 1.3.1 throughout the paper.

Unless otherwise stated, K will denote a compact connected Lie group and $G = K^{\mathbb{C}}$ its complexification, which is a complex connected reductive linear algebraic group.

4.1 Multiplicity free $U(2)$ -actions with trivial principal isotropy group

Let M be a multiplicity free $U(2)$ -manifold with trivial principal isotropy group. It follows from theorem 1.3.9 and example 1.3.8 that “near” a vertex lying on the wall of the Weyl chamber \mathfrak{t}_+ , the momentum polytope $\mathcal{P}(M)$ of M “looks like” the weight monoid of a smooth affine spherical $GL(2)$ -variety. We distill table 4.1 of all relevant smooth affine spherical $GL(2)$ -varieties from a result in [PPVS18]. This then allows us to make the conditions (1.3.14) and (1.3.15) very concrete in proposition 4.1.3.

Weight monoids of smooth affine spherical $GL(2)$ -varieties

Table 5 in [PPVS18] contains all the smooth affine spherical $(SL(2) \times \mathbb{C}^{\times})$ -varieties and their weight monoids. We briefly explain how to use this classification to explicitly determine the weight monoids of smooth affine $GL(2)$ -spherical varieties. We will make use of the notation in example 1.3.1. In particular, the weight lattice Λ of $GL(2)$ is spanned by the weights ω_1, ω_2 .

As in [PPVS18] we choose

$$H = \left\{ \begin{pmatrix} a & 0 \\ 0 & a^{-1} \end{pmatrix} : a \in \mathbb{C}^{\times} \right\} \times \mathbb{C}^{\times}$$

as the maximal torus and

$$U = \left\{ \begin{pmatrix} 1 & b \\ 0 & 1 \end{pmatrix} : b \in \mathbb{C} \right\} \times \{1\}$$

as the maximal unipotent subgroup of $\mathrm{SL}(2) \times \mathbb{C}^\times$ normalized by H . The weights $\omega : H \rightarrow \mathbb{C}^\times$ and $\varepsilon : H \rightarrow \mathbb{C}^\times$ defined by

$$\omega \left(\begin{pmatrix} a & 0 \\ 0 & a^{-1} \end{pmatrix}, z \right) = a, \text{ and } \varepsilon \left(\begin{pmatrix} a & 0 \\ 0 & a^{-1} \end{pmatrix}, z \right) = z$$

span the weight lattice $\mathrm{Hom}(H, \mathbb{C}^\times)$ of $\mathrm{SL}(2) \times \mathbb{C}^\times$ and the monoid of dominant weights corresponding to U is

$$\langle \omega, \varepsilon, -\varepsilon \rangle_{\mathbb{N}} \subset \mathrm{Hom}(H, \mathbb{C}^\times).$$

We define the isogeny

$$\varphi : \mathrm{SL}(2) \times \mathbb{C}^\times \rightarrow \mathrm{GL}(2) : (A, z) \mapsto zA \tag{4.1.1}$$

and denote the induced (injective) map $\Lambda \rightarrow \mathrm{Hom}(H, \mathbb{C}^\times)$ on weight lattices by φ^* . Then $\Gamma \subset \Lambda^+$ is the weight monoid of a smooth affine spherical $\mathrm{GL}(2)$ -variety if and only if $\varphi^*(\Gamma) \subset \langle \omega, \varepsilon, -\varepsilon \rangle_{\mathbb{N}}$ is the weight monoid of a smooth affine spherical $(\mathrm{SL}(2) \times \mathbb{C}^\times)$ -variety. Since

$$\varphi^*(\omega_1) = \omega + \varepsilon \text{ and } \varphi^*(\omega_2) = 2\varepsilon$$

we have

$$\varphi^*(\Lambda) = \{a\omega + b\varepsilon : a \equiv b \pmod{2}\}$$

and it follows that the images under φ^* of the weight monoids of smooth affine spherical $\mathrm{GL}(2)$ -varieties are exactly those weight monoids in [PPVS18, Table 5] which are subsets of $\{a\omega + b\varepsilon : a \equiv b \pmod{2}\}$.

In view of part (b) of theorem 1.3.9 we restrict ourselves to those weight monoids Γ of smooth affine spherical $\mathrm{GL}(2)$ -varieties such that the cone $\mathbb{R}_{\geq 0}\Gamma$ generated by Γ is pointed (as defined in remark 1.3.4(a)) and such that $\mathbb{Z}\Gamma = \Lambda$. This yields the weight monoids listed in table 4.1. In fact, in view of Knop's condition (1.3.15), we list the *weight cones* $\mathbb{R}_{\geq 0}\Gamma \subset \mathfrak{t}_+$ instead of the weight monoids. The cone $\mathbb{R}_{\geq 0}\Gamma$ determines Γ because we have fixed the lattice $\mathbb{Z}\Gamma$ generated by Γ to be Λ and because of the equality $\Gamma = \mathbb{Z}\Gamma \cap \mathbb{R}_{\geq 0}\Gamma$, which follows from the fact that smooth varieties are normal. In summary, these computations yield the following proposition.

Proposition 4.1.1. *If X is a smooth affine spherical $\mathrm{GL}(2)$ -variety such that $\mathbb{Z}\Gamma(X) = \Lambda$ and such that $\mathbb{R}_{\geq 0}\Gamma(X)$ is pointed, then $\mathbb{R}_{\geq 0}\Gamma(X)$ is one of the cones listed in table 4.1.*

Remark 4.1.2. As they provide local models of multiplicity free $\mathrm{U}(2)$ -manifolds with trivial principal isotropy group, we have included in table 4.1 the (unique) smooth affine spherical $\mathrm{GL}(2)$ -varieties X that realize the listed weight cones $\mathbb{R}_{\geq 0}\Gamma(X)$. We leave the verification that each variety X in the table has the given weight cone to the reader. This can be deduced from [PPVS18, Table 5] using the isogeny φ defined in (4.1.1) or by using basic facts in the representation theory of $\mathrm{GL}(2)$ to determine the highest weights of $\mathrm{GL}(2)$ that occur in the coordinate ring $\mathbb{C}[X]$ of X .

Table 4.1: Pointed weight cones of smooth affine spherical $\mathrm{GL}(2)$ -varieties X with $\mathbb{Z}\Gamma(X) = \Lambda$. The ‘‘Case’’ numbers refer to those in [PPVS18, Table 5]

| Case | X | $\mathbb{R}_{\geq 0}\Gamma(X)$ | parameters |
|-----------------------------------------------------------------------------------------|--------------------------------------------------------------------------------------------------------------------|-------------------------------------------------------------------------------------------|---------------------------------------------|
| 11 | $(\mathbb{C}^2 \otimes \mathbb{C}_{\det^{-(k+1)}}) \times \mathbb{C}_{\det^{-\ell}}$ | $\mathrm{cone}((k+1)\varepsilon_1 + k\varepsilon_2, \ell(\varepsilon_1 + \varepsilon_2))$ | $k \in \mathbb{Z},$ $\ell \in \{1, -1\}$ |
| 14 | $\mathrm{GL}(2) \times_{T^{\mathbb{C}}} \mathbb{C}_{-(j\alpha + \varepsilon_1)}$ | $\mathrm{cone}(\alpha, j\alpha + \varepsilon_1)$ | $j \in \mathbb{N}$ |
| 14 | $\mathrm{GL}(2) \times_{T^{\mathbb{C}}} \mathbb{C}_{-(j\alpha - \varepsilon_2)}$ | $\mathrm{cone}(\alpha, j\alpha - \varepsilon_2)$ | $j \in \mathbb{N}$ |
| 15 | $\mathrm{GL}(2) / \left\{ \begin{pmatrix} z^j & 0 \\ 0 & z^{j+1} \end{pmatrix} : z \in \mathbb{C}^\times \right\}$ | $\mathrm{cone}(j\alpha + \varepsilon_1, j\alpha - \varepsilon_2)$ | $j \in \mathbb{N}$ |
| $\alpha = \varepsilon_1 - \varepsilon_2$ as in example 1.3.1. | | | |
| In Case 11, \mathbb{C}^2 stands for the defining representation of $\mathrm{GL}(2)$. | | | |

Momentum polytopes

In proposition 4.1.3 we specialize Knop’s theorem 1.3.9 to the case $K = \mathrm{U}(2)$. We continue to use the notation in example 1.3.1. In particular, $\alpha = \varepsilon_1 - \varepsilon_2$ is the simple root of $\mathrm{U}(2)$. Combining table 4.1 with theorem 1.3.9 we obtain the following.

Proposition 4.1.3. *Let \mathcal{P} be a convex polytope in \mathfrak{t}_+ . Then \mathcal{P} is the momentum polytope of a (unique) multiplicity free $\mathrm{U}(2)$ -manifold with trivial principal isotropy group if and only if all of the following conditions are satisfied:*

- (1) $\dim \mathcal{P} = 2$;
- (2) \mathcal{P} is rational with respect to Λ , i.e. for every two vertices a, b of \mathcal{P} connected by the edge $[a, b]$ of \mathcal{P} , the intersection $\mathbb{R}(b - a) \cap \Lambda$ is nonempty (we will denote the primitive elements of Λ on the extremal rays of the cone $\mathbb{R}_{\geq 0}(\mathcal{P} - a)$ by ρ_1^a, ρ_2^a);
- (3) (Delzant) If a is a vertex of \mathcal{P} with $\langle \alpha^\vee, a \rangle > 0$, then (ρ_1^a, ρ_2^a) is a basis of Λ ;
- (4) If a is a vertex of \mathcal{P} with $\langle \alpha^\vee, a \rangle = 0$, then $\{\rho_1^a, \rho_2^a\}$ is one of the following sets:

$$\{\varepsilon_1 + \varepsilon_2, k(\varepsilon_1 + \varepsilon_2) + \varepsilon_1\} \quad \text{for some } k \in \mathbb{Z}; \quad (4.1.2)$$

$$\{-(\varepsilon_1 + \varepsilon_2), k(\varepsilon_1 + \varepsilon_2) + \varepsilon_1\} \quad \text{for some } k \in \mathbb{Z}; \quad (4.1.3)$$

$$\{\alpha, j\alpha + \varepsilon_1\} \quad \text{for some } j \in \mathbb{N}; \quad (4.1.4)$$

$$\{\alpha, j\alpha - \varepsilon_2\} \quad \text{for some } j \in \mathbb{N}; \quad (4.1.5)$$

$$\{j\alpha + \varepsilon_1, j\alpha - \varepsilon_2\} \quad \text{for some } j \in \mathbb{N}. \quad (4.1.6)$$

Proof. Thanks to Knop’s theorem 1.3.9, the cones in the third column of table 4.1 describe the ‘‘local’’ shape, near a vertex that lies on the wall of the Weyl chamber \mathfrak{t}_+ , of the momentum polytope \mathcal{P} of a multiplicity free $\mathrm{U}(2)$ -manifold with trivial principal isotropy group. If a is a vertex of \mathcal{P} that lies in the interior of \mathfrak{t}_+ , we have $(K_a)^{\mathbb{C}} = T^{\mathbb{C}}$. The shape of \mathcal{P} near a must be as described in part (3) of the proposition due to the well-known structure

of the weight monoids of smooth affine toric varieties (see, e.g. [Ful93, Section 2.1]). The proposition follows. \square

In remark 4.1.4 we give some geometric information related to vertices of the momentum polytopes under consideration in proposition 4.1.3. We first introduce some additional notation. Suppose (M, μ) is a multiplicity free $U(2)$ -manifold with momentum polytope \mathcal{P} . Let

$$\Psi : M \rightarrow \mathcal{P} \subset \mathfrak{t}_+, m \mapsto \mu(K \cdot m) \cap \mathfrak{t}_+ \quad (4.1.7)$$

be the **invariant momentum map** of M and let $\mu_T : M \rightarrow \mathfrak{t}^*$ be the momentum map of M considered as a T -manifold, that is $\mu_T = r \circ \mu$, where $r : \mathfrak{k}^* \rightarrow \mathfrak{t}^*$ is the restriction map. We recall from remark 1.3.7(b) that every fiber of Ψ is a K -orbit and from proposition 1.3.5 that $\mu_T(M)$ is the convex hull of $\mathcal{P} \cup s_\alpha(\mathcal{P})$.

Remark 4.1.4 (Vertices and fixpoints). Let \mathcal{P} be a polytope satisfying the conditions in proposition 4.1.3 and let M be the multiplicity free $U(2)$ -manifold with trivial principal isotropy group such that $\mathcal{P}(M) = \Psi(M) = \mathcal{P}$. The local models X of M given in table 4.1 yield the following information (see also remark 1.3.10(??)).

- (a) If a is as in case (3) of proposition 4.1.3, $\Psi^{-1}(a)$ contains exactly two T -fixpoints p_1, p_2 and $\mu_T(p_1) = s_\alpha(\mu_T(p_2))$.
- (b) If the extremal rays at a are those in eq. (4.1.2) or eq. (4.1.3), then there is a unique T -fixpoint p in $\Psi^{-1}(a)$. Moreover $\mu_T(p) = a$ and p is even fixed by $U(2)$.
- (c) In the cases of eqs. (4.1.4) and (4.1.5), there are exactly two T -fixpoints p_1, p_2 in $\Psi^{-1}(a)$. Moreover $\mu_T(p_1) = \mu_T(p_2) = a$.
- (d) In the case of eq. (4.1.6), $\Psi^{-1}(a)$ does not contain any T -fixpoints.

Invariant compatible complex structures

We recall that a complex structure J on a symplectic manifold (M, ω) is called *compatible* if (M, ω, J) is Kähler. In this section we present a generalization of a criterion of Woodward's for the existence of a $U(2)$ -invariant compatible complex structure on a multiplicity free $U(2)$ -manifold. More precisely, in [Woo98b, Theorem 8.8], Woodward provided such a criterion for a certain class of multiplicity free $SO(5)$ -manifolds and remarked that it could be adapted to other rank 2 groups. In case the acting group is $U(2)$, Woodward's criterion applies to those multiplicity free $U(2)$ -manifolds with trivial principal isotropy whose momentum polytope has a vertex on the wall of the Weyl chamber such that, near this vertex, the momentum polytope looks like one of the cones spanned by the vectors in (4.1.6). Thanks to the work [MT12] of J. Martens and M. Thaddeus on non-Abelian symplectic cutting we can show that his criterion can be used to decide the existence of a $U(2)$ -invariant compatible complex structure for any multiplicity free $U(2)$ -manifold with trivial principal isotropy, see proposition 4.1.7. In the proof of proposition 4.1.7 we use the so-called *extension criterion* of

Tolman [Tol98] to show in proposition 4.1.17 that a multiplicity free $U(2)$ -manifold with trivial principal isotropy group carries a $U(2)$ -invariant compatible complex structure if and only if it carries a T -invariant compatible complex structure. Woodward had proved an analogous statement for certain multiplicity free $SO(5)$ -manifolds in [Woo98a, Theorem 9.1]. Proposition 4.1.17 also gives a second Kählerizability criterion for our $U(2)$ -manifolds in terms of the T -momentum polytope and the images of the T -fixpoints under the T -momentum map.

Recall that the wall of the Weyl chamber \mathfrak{t}_+ of $U(2)$ is its subset $\{\lambda \in \mathfrak{t}^* : \langle \alpha^\vee, \lambda \rangle = 0\}$, where α^\vee is the simple coroot as in (1.3.2) of example 1.3.1.

Definition 4.1.5. Let \mathcal{P} be a 2-dimensional polytope in the Weyl chamber \mathfrak{t}_+ of $U(2)$, let F be an edge of \mathcal{P} and let \mathbf{n}_F be an inward-pointing normal vector to F . We call F a **positive** edge of \mathcal{P} if $\langle \alpha^\vee, \mathbf{n}_F \rangle > 0$.

Remark 4.1.6. It follows from proposition 4.1.3 that if the momentum polytope $\mathcal{P}(M)$ of a multiplicity free $U(2)$ -manifold with trivial principal isotropy group has exactly one vertex a on the wall of \mathfrak{t}_+ , then $\mathbb{R}_{\geq 0}(\mathcal{P}(M) - a)$ is the cone spanned by one of the sets $\{\rho_1^a, \rho_2^a\}$ in eqs. (4.1.4) to (4.1.6) of that proposition. In particular, $\mathcal{P}(M)$ has one or two positive edges that contain a .

Here is the announced generalization for $U(2)$ of Woodward's Kählerizability criterion [Woo98b, Theorem 8.8]. Its formal proof will be given on page 55.

Proposition 4.1.7. *Let M be a multiplicity free $U(2)$ -manifold with trivial principal isotropy group. Then M admits a $U(2)$ -invariant compatible complex structure if and only if the following property holds: if the momentum polytope $\mathcal{P}(M)$ of M has exactly one vertex on the wall of \mathfrak{t}_+ , then every positive edge of $\mathcal{P}(M)$ contains that vertex.*

Remark 4.1.8. With a straightforward adaptation of the proof of Proposition 7.27 and Corollary 7.28 in [CFPVS20] proposition 4.1.7 can also be proved by applying Theorem 7.16 of *loc.cit.*, which gives a (rather technical) general criterion for the existence of an invariant compatible complex structure on a multiplicity free manifold, using the combinatorial theory of spherical varieties.

Example 4.1.9 (Woodward). In [Woo98a], Woodward showed that the multiplicity free $U(2)$ -manifold M with momentum polytope

$$\mathcal{P}(M) = \text{conv}(0, \varepsilon_1, -\varepsilon_2, 3\varepsilon_1 - \varepsilon_2)$$

is not Kählerizable. This fact can be deduced immediately from proposition 4.1.7: the edge of $\mathcal{P}(M)$ connecting the vertices ε_1 and $3\varepsilon_1 - \varepsilon_2$ is positive, but does not contain the vertex 0 of $\mathcal{P}(M)$ that lies on the wall of the Weyl chamber. A picture of $\mathcal{P}(M)$ can be found on page 54: it is the trapezoid with vertices $0, v_1, v_2$ and v_3 on the right in fig. 4.1. Similarly, the multiplicity free $U(2)$ -manifold with momentum polytope

$$\text{conv}(0, \varepsilon_1, \alpha, 3\varepsilon_1 - \varepsilon_2)$$

is not Kählerizable, because the edge connecting ε_1 and $3\varepsilon_1 - \varepsilon_2$ is positive and does not contain the vertex 0. This polytope is the trapezoid with vertices v_0, v_1, v_2 and v_3 on the right in fig. 4.2. This kind of polytope was not covered by the criterion in [Woo98a].

The following lemma establishes a first part of proposition 4.1.7.

Lemma 4.1.10. *If M is a multiplicity free $U(2)$ -manifold whose momentum polytope \mathcal{P} does not have exactly one vertex on the wall of the Weyl chamber \mathfrak{t}_+ , then M admits a $U(2)$ -invariant complex structure.*

Proof. Our strategy is inspired by [Woo98a, §3] and uses E. Lerman’s *symplectic cutting* [Ler95]; see also [LMTW98]. We start with a certain multiplicity free (non-compact) $U(2)$ -manifold M_1 admitting a second Hamiltonian action of the maximal torus T of $U(2)$ that commutes with the $U(2)$ -action and such that $\phi(m) = \Psi(m)$ for all $m \in M$, where $\phi : M_1 \rightarrow \mathfrak{t}^*$ is the momentum map of the second T -action. We then perform a sequence of symplectic cuts (respecting the actions of both $U(2)$ and T) until the momentum polytope has the desired shape \mathcal{P} . Because \mathcal{P} is of Delzant type (by proposition 4.1.3), it can be obtained from $\phi(M_1) = \Psi(M_1)$ by a finite sequence of cuts along hyperplanes such that, at each stage, the corresponding symplectic cut yields a smooth manifold.

We first assume that an entire edge of the momentum polytope \mathcal{P} lies on the Weyl wall. Let \mathbf{v} be one of the two vertices of \mathcal{P} on the Weyl wall and suppose that

$$\text{cone}(\mathcal{P} - \mathbf{v}) = \text{cone}(-(\varepsilon_1 + \varepsilon_2), \varepsilon_1 + k(\varepsilon_1 + \varepsilon_2)) \text{ for some } k \in \mathbb{Z}.$$

We set $M_1 = \mathbb{C}^3$ and equip it with the $U(2)$ -action given by

$$g \cdot ((z_1, z_2), z_3) := ((\det(g)^{-(k+1)} \cdot g) \cdot (z_1, z_2), \det(g) \cdot z_3)$$

(this is precisely the action in the first row of table 4.1 for $\ell = -1$) and the standard Hamiltonian $U(2)$ -structure as representation of $U(2)$; see e.g. [Sja98, Example 2.1]. The explicit expression for the invariant momentum map Ψ is then

$$\Psi : M_1 \rightarrow \mathfrak{t}_+, \quad \Psi(z_1, z_2, z_3) = \frac{\pi}{2}(|z_1|^2 + |z_2|^2)((k+1)\varepsilon_1 + k\varepsilon_2) - \frac{\pi}{2}|z_3|^2(\varepsilon_1 + \varepsilon_2).$$

Indeed, the restriction of the momentum map of M_1 to the cross-section $0 \oplus \mathbb{C} \oplus \mathbb{C}$ takes values in \mathfrak{t}^* and is thus given by the momentum map of the T -action on $0 \oplus \mathbb{C} \oplus \mathbb{C}$, which is

$$(0, z_2, z_3) \mapsto \frac{\pi}{2}|z_2|^2((k+1)\varepsilon_1 + k\varepsilon_2) - \frac{\pi}{2}|z_3|^2(\varepsilon_1 + \varepsilon_2).$$

As Ψ is constant on $U(2)$ -orbits, it now follows that it is of the asserted shape.

We also equip M_1 with the following additional action of T :

$$(t_1, t_2) \cdot (z_1, z_2, z_3) = (t_2(t_1 t_2)^{-(k+1)} z_1, t_2(t_1 t_2)^{-(k+1)} z_2, t_1 t_2 z_3).$$

This action is effective and commutes with the $U(2)$ -action. More importantly, it is Hamiltonian with momentum map ϕ equal to Ψ . We can use ϕ to perform the aforementioned sequence of symplectic cuts until the momentum image of ϕ is equal to \mathcal{P} . Since ϕ and Ψ coincide on M_1 , they will coincide after every cut. By the uniqueness part of Knop’s theorem 1.3.9, the $U(2)$ -manifold obtained at the end of this process is M . Due to basic properties of the symplectic cut, the manifold is still Kähler.

If \mathcal{P} lies in the interior of the Weyl chamber, then we can still start with (for example) M_1 (for some suitable choice of the parameter k) and we can again cut $\Psi(M_1) = \phi(M_1)$ until we reach \mathcal{P} . \square

Remark 4.1.11. The reason that the resulting manifold after all the symplectic cuts in the proof of lemma 4.1.10 is Kähler, is that the cuts are made with respect to circle subgroups of T and that action of T on M with momentum map ϕ is a *global* action which extends to an action of the complexification $T^{\mathbb{C}}$ of T . In Woodward’s non-Kählerizable example [Woo98a, §3], only a local circle action was used to perform the cut; in general one does not obtain a compatible Kähler structure after such a cut.

Remark 4.1.12. The Kähler structures constructed in the proof of lemma 4.1.10 are in fact toric Kähler structures for a torus of rank 3. Indeed, the constructed manifold carries an induced $T \times T$ -action after every cut. Its kernel always has dimension 1, which means that it descends to a multiplicity free action of a torus of rank 3.

We now use [MT12, Corollary 4] to establish the next part of proposition 4.1.7.

Lemma 4.1.13. *Let M be a multiplicity free $U(2)$ -manifold with trivial principal isotropy group. Suppose that the momentum polytope \mathcal{P} of M has exactly one vertex a on the wall of \mathfrak{t}_+ . If every positive edge of \mathcal{P} contains the vertex a , then M admits a $U(2)$ -invariant compatible complex structure.*

Proof. It follows from proposition 4.1.3 that $\{\rho_1^a, \rho_2^a\}$ is one of the sets in (4.1.4), (4.1.5) or (4.1.6). Let M_1 be the corresponding smooth affine spherical $GL(2)$ -variety in table 4.1, that is, $M_1 = GL(2) \times_{T^{\mathbb{C}}} \mathbb{C}_{-(j\alpha+\varepsilon_1)}$ when $\{\rho_1^a, \rho_2^a\}$ is the set in (4.1.4), $M_1 = GL(2) \times_{T^{\mathbb{C}}} \mathbb{C}_{-(j\alpha-\varepsilon_2)}$ when $\{\rho_1^a, \rho_2^a\}$ is the set in (4.1.5) and $M_1 = GL(2) \left/ \left\{ \begin{pmatrix} z^j & 0 \\ 0 & z^{j+1} \end{pmatrix} : z \in \mathbb{C}^\times \right\} \right.$ when $\{\rho_1^a, \rho_2^a\}$ is the set in (4.1.6). As in [Sja98, §4.1], we view M_1 as a Hamiltonian $U(2)$ -manifold by embedding it into a unitary representation of $U(2)$. Let $\Psi : M_1 \rightarrow \mathfrak{t}_+$ be the corresponding invariant momentum map. It follows from [Sja98, Theorem 4.9] that $\Psi(M_1) = \text{cone}\{\rho_1^a, \rho_2^a\}$. By translating the momentum map of M_1 by a , we ensure that $\Psi(M_1) = a + \text{cone}\{\rho_1^a, \rho_2^a\} = a + \text{cone}(\mathcal{P} - a)$, in other words, that $\Psi(M_1)$ is equal to \mathcal{P} in a neighborhood of a . One can now apply non-abelian symplectic cutting to M_1 to obtain a multiplicity free $U(2)$ -manifold with momentum polytope \mathcal{P} . By Knop’s uniqueness result in theorem 1.3.9, this multiplicity free manifold has to be M . Because, as mentioned in remark 4.1.11, non-abelian symplectic cutting is a local construction which cannot be realized by “global” symplectic reduction, this does not yet guarantee that M is Kähler, even though M_1 was.

Nevertheless, under the assumptions of the current lemma, [MT12, Corollary 4] yields that M can be constructed as the symplectic reduction of a symplectic $U(2)$ -manifold \widetilde{M} , which is Kähler because M_1 is. It then follows that M is Kähler by the general properties of symplectic reduction. The key point which allows us to apply *loc.cit.* is that

$$\mathcal{P} = \Psi(M_1) \cap \mathbb{Q}, \tag{4.1.8}$$

where \mathbb{Q} is an *outward-positive* polyhedral set, using the terminology of [MT12, Definition 3]. To describe \mathbb{Q} , let $\mathbf{n}_1, \mathbf{n}_2, \dots, \mathbf{n}_r$ be inward-pointing normal vectors to the r edges of \mathcal{P} that do not contain the vertex a of \mathcal{P} lying on the wall of \mathfrak{t}_+ . By assumption

$$\langle \alpha^\vee, \mathbf{n}_i \rangle \leq 0 \quad \text{for all } i \in \{1, 2, \dots, r\}. \tag{4.1.9}$$

Let $\eta_1, \eta_2, \dots, \eta_r \in \mathbb{R}$ be such that, for each $i \in \{1, 2, \dots, r\}$,

$$\mathcal{P} \cap \{v \in \mathfrak{t}_+ : \langle v, \mathbf{n}_i \rangle = \eta_i\}$$

is the edge of \mathcal{P} to which \mathbf{n}_i is an inward-pointing normal. Now we set

$$\mathbf{Q} = \{v \in \mathfrak{t}_+ : \langle v, \mathbf{n}_i \rangle \geq \eta_i \text{ for all } i \in \{1, 2, \dots, r\}\}.$$

Then (4.1.8) holds, and (4.1.9) says precisely that \mathbf{Q} is outward-positive. As explained in [MT12, Remark 2], one may need to (and can) impose some extra inequalities to make \mathbf{Q} *universal* in the parlance of [MT12, Definition 2]. \square

Remark 4.1.14. In the situation of lemma 4.1.13, if \mathcal{P} has a positive edge not containing a , then it has one that is adjacent to an edge containing a . This follows from the convexity of \mathcal{P} .

For the final step in the proof of proposition 4.1.7, we will make use of work of S. Tolman's. In [Tol98], she constructed an example of a Hamiltonian T -space of complexity one in dimension six that does not admit a T -invariant compatible complex structure. She proved this by checking that her example does not satisfy a certain *extension criterion* and showing that this criterion is necessary for a T -invariant compatible complex structure to exist. For the convenience of the reader, we will recall this criterion here together with the definitions necessary to formulate it. The criterion applies to compact Hamiltonian $U(1)^n$ -manifolds for any $n \in \mathbb{N}$, but to avoid introducing additional notation, we will use T for the acting torus, as this is the setting where we will apply it. We refer to [Tol98, §§2,3] for details.

By the **x-ray** of M , we mean its orbit type stratification

$$\mathcal{X} = \bigcup_{H \text{ subgroup of } T} \{\text{connected components of } M^H\}$$

together with the convex polytopes that are the images of its elements under the T -momentum map μ_T . We say that a convex polytope $\Delta \subset \mathfrak{t}^*$ (resp. a strictly convex cone $C \subset \mathfrak{t}^*$) is **compatible** with this x-ray if (there exists a neighborhood U of the vertex of C such that) for each face σ of Δ (resp. C), we can choose $X_\sigma \in \mathcal{X}$ such that

$$\dim(\mu_T(X_\sigma)) = \dim(\sigma), \tag{4.1.10}$$

$$\sigma \subset \mu_T(X_\sigma) \text{ (resp. } \sigma \cap U \subset \mu_T(X_\sigma)), \text{ and} \tag{4.1.11}$$

$$X_\sigma \subset X_{\sigma'} \text{ whenever } \sigma \text{ and } \sigma' \text{ are faces of } \Delta \text{ (resp. } C) \text{ with } \sigma \subset \sigma'. \tag{4.1.12}$$

We say that Δ is an **extension** of C when there exists a neighborhood U of the vertex of C with $C \cap U = \Delta \cap U$.

Definition 4.1.15. An x-ray satisfies the **extension criterion** if every compatible strictly convex cone admits an extension to a compatible convex polytope.

Theorem 4.1.16 ([Tol98, Theorem 3.3]). *Let M be a Hamiltonian T -manifold that does not satisfy the extension criterion. Then M does not admit a T -invariant compatible complex structure.*

It is clear that a compatible convex cone of dimension one always admits an extension to a compatible convex polytope, so this criterion only needs to be checked for compatible strictly convex cones of dimension at least two. On the other hand, since our μ_T takes values in a vector space of dimension 2, we only need to check this condition for compatible strictly convex cones of dimension exactly two. The vertices of those have to be image of a T -fixed point p , and the edges locally have to be images of weight spaces of the corresponding isotropy representation of T at p . Consequently, we can describe every such cone by giving two line segments starting at $\mu_T(p)$ that correspond to linearly independent weights of the isotropy representation at p , and any such line segment can be described by a pair of points in $\mathcal{P}_T = \mu_T(M)$, one of which is $\mu_T(p)$. We will use this identification throughout.

Combinatorially linking Tolman's criterion to the Kählerizability criterion of proposition 4.1.7 we now also extend [Woo98a, Theorem 9.1] of Woodward's about certain multiplicity free $\mathrm{SO}(5)$ -manifolds to multiplicity free $\mathrm{U}(2)$ -manifolds with trivial principal isotropy whose momentum polytope intersects the Weyl wall in one point. We also rephrase our Kählerizability criterion in terms of the T -momentum polytope and the T -fixpoints.

Proposition 4.1.17. *Let M be a multiplicity free $\mathrm{U}(2)$ -manifold with trivial principal isotropy group whose momentum polytope \mathcal{P} intersects the Weyl wall at exactly one point. Then the following are equivalent:*

- (1) *Every positive edge of \mathcal{P} contains the vertex a of \mathcal{P} lying on the Weyl wall.*
- (2) *M admits a $\mathrm{U}(2)$ -invariant compatible complex structure.*
- (3) *M admits a T -invariant compatible complex structure.*
- (4) *The x -ray of M satisfies the extension criterion.*
- (5) *The set M^T is mapped to the boundary of $\mathcal{P}_T = \mu_T(M)$ under the T -momentum map μ_T .*

Proof. First we show that (5) implies (1). If (1) does not hold, then \mathcal{P} contains a positive edge that does not meet the wall of the Weyl chamber. This means that the two vertices \mathbf{v} and \mathbf{w} adjacent to this edge are the images under μ as well as under μ_T of T -fixed points in M , see theorem 1.3.3(a). Call the vertex of \mathcal{P} on the wall of the Weyl chamber v_0 , and set $\mathbf{v}' = s_\alpha(\mathbf{v})$, $\mathbf{w}' = s_\alpha(\mathbf{w})$. Then it follows from proposition 1.3.5 that the polytope

$$\mathrm{conv}(v_0, \mathbf{v}, \mathbf{v}', \mathbf{w}, \mathbf{w}') \tag{4.1.13}$$

is a subset of \mathcal{P}_T . Using that the edge (\mathbf{v}, \mathbf{w}) of \mathcal{P} is positive, elementary geometric considerations show that \mathbf{v} or \mathbf{w} lies in the interior of the polytope (4.1.13), and therefore not on the boundary of \mathcal{P}_T . This shows that (5) does not hold.

We turn to the implication “(1) \Rightarrow (5).” Let $m \in M^T$. First observe that $\mu(m) \in (\mathfrak{k}^*)^T = \mathfrak{k}^*$ by the equivariance of μ , and therefore that $\mu_T(m) = \mu(m)$. Next, $\mu_T(m) \in \{\Psi(m), s_\alpha(\Psi(m))\}$ thanks to the well-known isomorphism $\mathfrak{k}^*/K \cong \mathfrak{k}^*/\{e, s_\alpha\}$ induced by the restriction map $\mathfrak{k}^* \rightarrow \mathfrak{k}^*$. Furthermore, $\Psi(m)$ is a vertex of $\mathcal{P} = \Psi(M)$. Indeed, if $\Psi(m)$ lies on the Weyl wall, this is true by assumption and if $\Psi(m)$ lies in the interior of the Weyl chamber, then it follows from theorem 1.3.3(b) because $\dim_{\mathbb{R}} T_m(K \cdot m) = 2$. We first consider the case that $\mu_T(m)$ lies on the Weyl wall. Then $\mu_T(m) = v_0$ and it follows from parts (c) and (d) of remark 4.1.4 that v_0 is of type (4.1.4) or of type (4.1.5). Let (v_0, \mathbf{v}) be the edge of \mathcal{P} that is perpendicular to the Weyl wall. Then, using proposition 1.3.5, one deduces that $(s_\alpha(\mathbf{v}), \mathbf{v})$ is an edge of \mathcal{P}_T and therefore that $v_0 = \mu_T(m)$ lies on the boundary of \mathcal{P}_T . Suppose now that (5) does not hold and that $m \in M^T$ is such that $\mu_T(m)$ does not lie on the boundary of \mathcal{P}_T . As we just saw, this implies that $\mu_T(m)$ does not lie on the Weyl wall. It follows from proposition 1.3.5 that the segment $[\mu_T(m), s_\alpha(\mu_T(m))] = [\Psi(m), s_\alpha(\Psi(m))]$, which is perpendicular to the Weyl wall, lies in the interior of \mathcal{P}_T . Therefore (at least) one of the two edges of \mathcal{P} adjacent to $\Psi(m)$ is positive and does not meet the Weyl wall, which means that (1) does not hold. We have shown that (5) follows from (1).

Next, we observe that (2) follows from (1) by lemma 4.1.13, that the implication “(2) \Rightarrow (3)” is trivial and that (4) follows from (3) by theorem 4.1.16.

In the remainder of the proof, we show that (4) implies (1). We label the vertices of \mathcal{P} clockwise from v_0 to v_n (starting at the wall), and we denote by v'_j the reflection $s_\alpha(v_j)$ of v_j across the Weyl wall. Note that for $j \neq 0$ the line segment (v_j, v'_j) is always the image of a connected component of $M^{Z(\mathrm{U}(2))}$, where $Z(\mathrm{U}(2))$ is the center of $\mathrm{U}(2)$, and that this connected component is a sphere except when an edge of \mathcal{P} adjacent to v_j is parallel to α , in which case it is 4-dimensional by theorem 1.3.3(b) together with remark 1.3.4(b).

We consider two cases, depending on whether the vertex v_0 is of type (4.1.4) (respectively of type (4.1.5), which is clearly equivalent) or of type (4.1.6). In each case, the edges of the x-ray are determined by \mathcal{P} in the following way:

- In the first case, there are the aforementioned connected components of $M^{Z(\mathrm{U}(2))}$ together with all spheres belonging to those edges (v_j, v_{j+1}) and (v'_j, v'_{j+1}) which are not parallel to α .
- In the second case, there are the connected components of $M^{Z(\mathrm{U}(2))}$ together with all spheres belonging to those edges (v_j, v_{j+1}) and (v'_j, v'_{j+1}) , $j \leq n-1$, which are not parallel to α , and on top the spheres belonging to (v_n, v'_1) and (v_1, v'_n) . The latter are included, because the horizontal edge starting from v_1 , for example, needs to end in one of v'_1, \dots, v'_n , and due to the convexity of the reflection of \mathcal{P} across the Weyl wall, the only possible endpoint is then v'_n .

Assume that we are in the second case: v_0 is of type (4.1.6). Suppose that (1) does not hold (a polytope illustrating this situation can be found on the right in fig. 4.1). By remark 4.1.14 and without loss of generality, we may assume that the positive edge is the edge (v_1, v_2) . Then v_1 and v'_1 are in the interior of \mathcal{P}_T . We claim that the compatible cone determined

by the pair of edges $(v_1, v'_1), (v_1, v'_n)$ does not admit an extension to a compatible convex polytope. Indeed, the edge (v'_1, v_n) emerging from v_n cannot be part of such a polytope (since this edge intersects the edge (v_1, v'_n) in a point which is not the image of a T -fixpoint) and neither can the edge (v'_1, v'_2) as convexity would not hold.

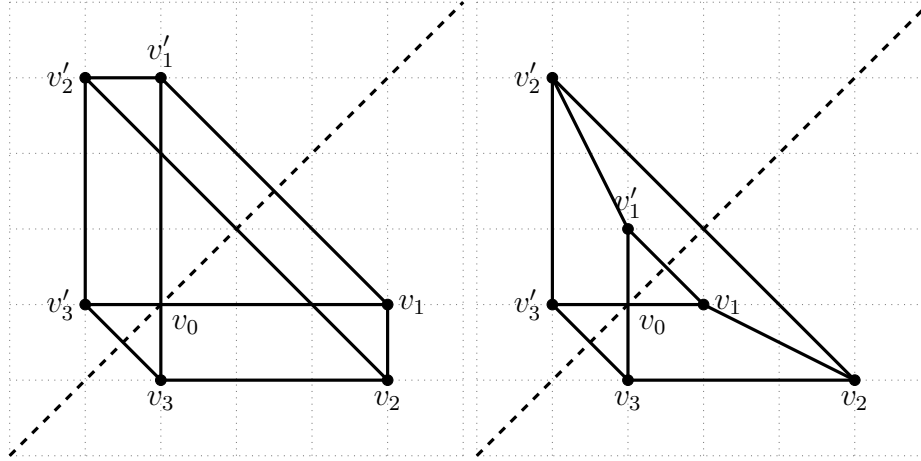

Figure 4.1: Two polytopes \mathcal{P} with v_0 of type (4.1.6) and their x-rays. The left x-ray satisfies the extension criterion, the right one does not.

Now assume that we are in the second case: v_0 is of type (4.1.4). Suppose again that (1) does not hold (such a polytope is given on the right in fig. 4.2). One of the compatible cones with vertex v_0 is spanned by the pairs of edges $(v_0, v'_1), (v_0, v_n)$. If it admitted an extension to a compatible convex polytope \mathcal{Q} , then the second edge of \mathcal{Q} adjacent to v'_1 would have to be (v'_1, v_1) , and the second edge emerging from v_1 would have to be (v_1, v_2) , which contradicts the convexity of \mathcal{Q} because (1) does not hold. \square

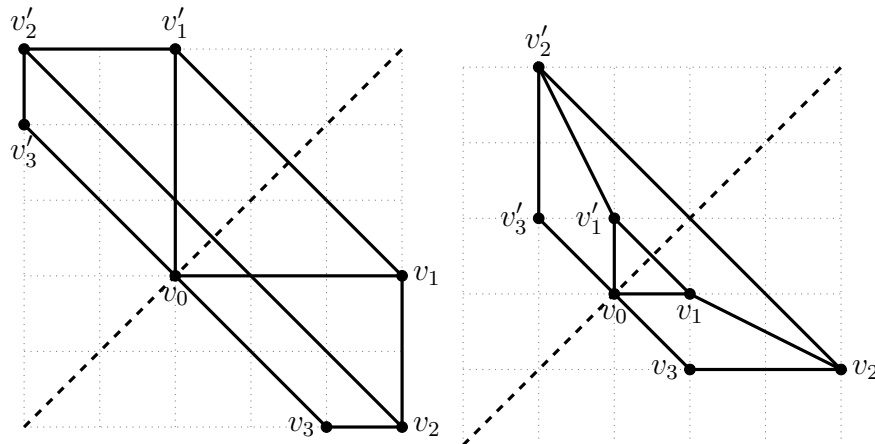

Figure 4.2: Two polytopes \mathcal{P} with v_0 of type (4.1.4) and their x-rays. The left x-ray satisfies the extension criterion, the right one does not.

Remark 4.1.18. The momentum polytopes in figs. 4.3 and 4.6 show that the equivalence of (5) and (1) of proposition 4.1.17 do not hold when \mathcal{P} does not meet the Weyl wall in exactly one point. On the other hand, proposition 4.1.7 tells us that when $\mathcal{P}(M)$ does not meet the Weyl wall in exactly one point, then the multiplicity free $U(2)$ -manifold M with trivial principal isotropy group always admits an invariant compatible complex structure, and therefore the equivalences (1) \Leftrightarrow (3) \Leftrightarrow (4) hold in this case as well.

Proof of proposition 4.1.7. The proposition immediately follows from lemma 4.1.10 and the equivalence of (1) and (2) in proposition 4.1.17. \square

4.2 Triangles

We continue to use the notation in example 1.3.1. In this section, we classify the multiplicity free $U(2)$ -manifolds with trivial principal isotropy group of which the momentum polytope is a triangle. The following lemma determines the *Delzant* triangles and will be used to describe the triangles in \mathfrak{t}_+ which can occur as momentum polytopes of such manifolds.

Lemma 4.2.1. *Let u, v and $w \in \mathfrak{t}^* = \Lambda \otimes_{\mathbb{Z}} \mathbb{R}$ such that*

$$v - u, w - u, w - v \in \Lambda \otimes_{\mathbb{Z}} \mathbb{Q}.$$

and let ρ_1, ρ_2, ρ_3 be the primitive elements of Λ such that

$$\mathbb{R}_{\geq 0}\rho_1 = \mathbb{R}_{\geq 0}(v - u), \mathbb{R}_{\geq 0}\rho_2 = \mathbb{R}_{\geq 0}(w - u), \mathbb{R}_{\geq 0}\rho_3 = \mathbb{R}_{\geq 0}(w - v).$$

Suppose (ρ_1, ρ_2) is a basis of Λ . Both pairs (ρ_1, ρ_3) and (ρ_2, ρ_3) are bases of Λ if and only if $\rho_3 = \rho_2 - \rho_1$.

Proof. The “if” statement is clear. To prove the converse, let $a, b \in \mathbb{Z}$ such that $\rho_3 = a\rho_1 + b\rho_2$. It follows from the assumption that (ρ_1, ρ_3) and (ρ_2, ρ_3) are bases of Λ , that $a, b \in \{1, -1\}$. The definitions of ρ_1, ρ_2, ρ_3 then imply that $a = -1$ and $b = 1$. \square

Recall from example 1.3.1 that $\alpha = \varepsilon_1 - \varepsilon_2$ is the simple root of $U(2)$.

Proposition 4.2.2. *The triangles in \mathfrak{t}_+ that occur as momentum polytopes of multiplicity free $U(2)$ -manifolds with trivial principal isotropy group are:*

1. $r(-\varepsilon_2) + s(\varepsilon_1 + \varepsilon_2) + t \cdot \text{conv}(0, a_1(-\varepsilon_2) + b_1\varepsilon_1, a_2(-\varepsilon_2) + b_2\varepsilon_1)$, where $r, t \in \mathbb{R}_{>0}$, $s \in \mathbb{R}$, $a_1, b_1, a_2, b_2 \in \mathbb{Z}$ with $\det \begin{pmatrix} a_1 & a_2 \\ b_1 & b_2 \end{pmatrix} = 1$ and $a_i + b_i \geq 0$ for each $i \in \{1, 2\}$;
2. $s(\varepsilon_1 + \varepsilon_2) + t \cdot \text{conv}(0, \ell(\varepsilon_1 + \varepsilon_2), k(\varepsilon_1 + \varepsilon_2) + \varepsilon_1)$, where $s \in \mathbb{R}$, $t \in \mathbb{R}_{>0}$, $k \in \mathbb{Z}$, $\ell \in \{-1, 1\}$;
3. $s(\varepsilon_1 + \varepsilon_2) + t \cdot \text{conv}(0, \alpha, j\alpha + \varepsilon_1)$, where $s \in \mathbb{R}$, $t \in \mathbb{R}_{>0}$, $j \in \mathbb{N}$

4. $s(\varepsilon_1 + \varepsilon_2) + t \cdot \text{conv}(0, \alpha, j\alpha - \varepsilon_2)$, where $s \in \mathbb{R}$, $t \in \mathbb{R}_{>0}$, $j \in \mathbb{N}$;

5. $s(\varepsilon_1 + \varepsilon_2) + t \cdot \text{conv}(0, \varepsilon_1, -\varepsilon_2)$, where $s \in \mathbb{R}$, $t \in \mathbb{R}_{>0}$.

Proof. Observe that the all the sets in eqs. (4.1.2) to (4.1.5) and the one in eq. (4.1.6) with $j = 0$ are bases of Λ . The proposition now follows from proposition 4.1.3 and lemma 4.2.1 once we prove the following claim: if $\mathcal{P} \subset \mathfrak{t}_+$ is a triangle satisfying conditions (2) and (3) of proposition 4.1.3 and a is a vertex of \mathcal{P} such that $\langle \alpha^\vee, a \rangle = 0$ and

$$\{\rho_1^a, \rho_2^a\} = \{j\alpha + \varepsilon_1, j\alpha - \varepsilon_2\} \quad \text{for some } j \in \mathbb{N},$$

then $j = 0$. We may assume that $\rho_1^a = j\alpha + \varepsilon_1$ and $\rho_2^a = j\alpha - \varepsilon_2$. Let b, c be the other two vertices of \mathcal{P} , such that $\mathbb{R}_{\geq 0}(b - a) = \mathbb{R}_{\geq 0}\rho_1^a$ and $\mathbb{R}_{\geq 0}(c - a) = \mathbb{R}_{\geq 0}\rho_2^a$ and write ρ for the primitive element of Λ on the ray $\mathbb{R}_{\geq 0}(c - b)$. Since (ρ, ρ_1^a) is a basis of Λ by condition (3) of proposition 4.1.3, there exist $m, n \in \mathbb{Z}$ such that $\rho_2^a = m\rho + n\rho_1^a$. Using that (ρ, ρ_2^a) is also a basis of Λ it follows that $n \in \{-1, 1\}$. As ρ_2^a belongs to the cone $\{p\rho + q\rho_1^a : p, q \in \mathbb{R}_{\geq 0}\}$ we obtain $n = 1$ and $m > 0$. Consequently $m\rho = \rho_2^a - \rho_1^a = -(\varepsilon_1 + \varepsilon_2)$. As $\rho \in \Lambda$ it follows that $\rho = -(\varepsilon_1 + \varepsilon_2)$. Using once more that (ρ, ρ_1^a) is a basis of Λ it follows that $j = 0$, which completes the proof of the claim. \square

For each triangle in proposition 4.2.2, Knop's theorem 1.3.9 guarantees the existence of a multiplicity free Hamiltonian $U(2)$ -manifold whose momentum polytope is that triangle. Theorem 4.2.3 below gives an explicit description of these manifolds. Propositions 4.2.5 to 4.2.9 provide the Hamiltonian structures.

Theorem 4.2.3. *Let \mathcal{Q} be one of the triangles listed in proposition 4.2.2 and let M be the (up to isomorphism) unique multiplicity free $U(2)$ -manifold with $\mathcal{P}(M) = \mathcal{Q}$ and trivial principal isotropy group. Then:*

- (a) *M is $U(2)$ -equivariantly diffeomorphic to the corresponding manifold listed in the second column of table 4.2.*
- (b) *M is isomorphic (as a Hamiltonian $U(2)$ -manifold) to the corresponding manifold listed in the second column of table 4.2 equipped with the Hamiltonian structure described in the proposition listed in the last column of table 4.2.*
- (c) *M has an invariant compatible complex structure J such that the complex manifold (M, J) , equipped with the action of $GL(2)$ that is the complexification of the $U(2)$ -action, is $GL(2)$ -equivariantly biholomorphic to the corresponding $GL(2)$ -variety listed in the third column of table 4.2.*

Proof. In each proposition listed in the fourth column of table 4.2, we define a structure of multiplicity free $U(2)$ -manifold on the smooth complex $GL(2)$ -variety M listed in the third column such that

- the momentum polytope of M is the corresponding triangle of proposition 4.2.2;

- the $U(2)$ -invariant complex structure that M carries by virtue of being a smooth complex $GL(2)$ -variety (cf. proposition 1.4.3) is compatible with the symplectic form on M ; and
- M , viewed as a differentiable manifold, is $U(2)$ -equivariantly diffeomorphic to the manifold listed in the second column of table 4.2.

Since, in each case, the $U(2)$ -action on M has a trivial principal isotropy group, all the assertions now follow from part (a) of Knop's theorem 1.3.9. \square

Table 4.2: Multiplicity free $U(2)$ -manifolds M with trivial principal isotropy group for which $\mathcal{P}(M)$ is a triangle, as asserted in theorem 4.2.3. The cases are numbered as in proposition 4.2.2.

| Case | M as $U(2)$ -manifold | M as $GL(2)$ -variety | Prop. |
|----------------------------------------------------------------------------------------------------------------|---------------------------------------------------------------------------------------------------------------------------------------------------------------------------------------------------------------------------------------------------------------------------------------------------------------------|------------------------------------------------------------------------------------------------------------------------------------------------------------------------------------------------------------------------------------------|-------|
| (1) | $U(2) \times_T \mathbb{P}(V)$, where $V = \mathbb{C} \oplus \mathbb{C}_{-\delta_1} \oplus \mathbb{C}_{-\delta_2}$, with $\delta_1 = a_1(-\varepsilon_2) + b_1\varepsilon_1$, $\delta_2 = a_2(-\varepsilon_2) + b_2\varepsilon_1$, $a_1, b_1, a_2, b_2 \in \mathbb{Z}$ as in proposition 4.2.2(1) | $GL(2) \times_{B^-} \mathbb{P}(V)$ | 4.2.8 |
| (2) | $\mathbb{P}((\mathbb{C}^2 \otimes \mathbb{C}_{\det^{-(k+1)}}) \oplus \mathbb{C}_{\det^{-\ell}} \oplus \mathbb{C})$, where $k \in \mathbb{Z}, \ell \in \{-1, 1\}$. | idem | 4.2.5 |
| (3) | $U(2) \times_T \mathbb{P}(\mathbb{C}^2 \oplus \mathbb{C}_{-j\alpha})$, where $j \in \mathbb{N}$. | $GL(2) \times_{B^-} \mathbb{P}(\mathbb{C}^2 \oplus \mathbb{C}_{-j\alpha})$ | 4.2.6 |
| (4) | $U(2) \times_T \mathbb{P}((\mathbb{C}^2)^* \oplus \mathbb{C}_{-j\alpha})$, where $j \in \mathbb{N}$. | $GL(2) \times_{B^-} \mathbb{P}((\mathbb{C}^2)^* \oplus \mathbb{C}_{-j\alpha})$ | 4.2.7 |
| (5) | $SO(5)/[SO(2) \times SO(3)]$, where $U(2)$ acts through $U(2) \hookrightarrow SO(4) \subset SO(5)$ | $SO(5, \mathbb{C})/P$, where $P \subset SO(5, \mathbb{C})$ is the minimal standard parabolic assoc. to the short simple root, $GL(2)$ acts through $GL(2) \hookrightarrow SO(4, \mathbb{C}) \subset SO(5, \mathbb{C})$. | 4.2.9 |
| \mathbb{C} always stands for the trivial representation. | | | |
| \mathbb{C}^2 stands for the defining representation of $GL(2)$ or its restriction to $U(2)$, T or B^- . | | | |

We will make use of the following standard fact, which follows directly from the definitions, taking into account that $\varepsilon_1 + \varepsilon_2 \in \mathfrak{t}^* \subset \mathfrak{u}(2)^*$ is a fixpoint for the coadjoint action of $U(2)$.

Lemma 4.2.4. *Let (M, ω_M, μ_M) be a compact Hamiltonian $U(2)$ -manifold with momentum polytope \mathcal{Q} . If $s \in \mathbb{R}, t \in \mathbb{R}_{>0}$, then*

$$\mu_M^{s,t} := t\mu_M + s(\varepsilon_1 + \varepsilon_2)$$

is a momentum map for the symplectic form $t\omega_M$ on M and the momentum polytope of the Hamiltonian $U(2)$ -manifold $(M, t\omega_M, \mu_M^{s,t})$ is

$$s(\varepsilon_1 + \varepsilon_2) + t \cdot \mathcal{Q}.$$

Furthermore, if (M, ω_M, μ_M) is multiplicity free, then so is $(M, t\omega_M, \mu_M^{s,t})$

The next proposition gives the multiplicity free $U(2)$ -manifold associated to the momentum polytope (2) of proposition 4.2.2. In what follows, we will write e_1, e_2 for the standard basis of \mathbb{C}^2 .

Proposition 4.2.5. *Let $k \in \mathbb{Z}$, $\ell \in \{-1, 1\}$. Let V be the $U(2)$ -representation*

$$V := (\mathbb{C}^2 \otimes \mathbb{C}_{\det^{-(k+1)}}) \oplus \mathbb{C}_{\det^{-\ell}} \oplus \mathbb{C} \cong V(\varpi_1 - (k+1)\varpi_2) \oplus V(-\ell\varpi_2) \oplus V(0).$$

- (a) *The projective space $\mathbb{P}(V)$, equipped with the Fubini-Study symplectic form and the momentum map $\mu_{\mathbb{P}(V)}$ of example 1.3.2, is a multiplicity free $U(2)$ -manifold with trivial principal isotropy group.*
- (b) *The T -fixpoints in $\mathbb{P}(V)$ are*

$$x_1 := [(e_1 \otimes 1) \oplus 0 \oplus 0], \quad x_2 := [(e_2 \otimes 1) \oplus 0 \oplus 0], \quad x_3 := [0 \oplus 1 \oplus 0], \quad x_4 := [0 \oplus 0 \oplus 1]$$

and their images under $\mu_{\mathbb{P}(V)}$ are (in the same order)

$$k(\varepsilon_1 + \varepsilon_2) + \varepsilon_2, \quad k(\varepsilon_1 + \varepsilon_2) + \varepsilon_1, \quad \ell(\varepsilon_1 + \varepsilon_2), \quad 0 \tag{4.2.1}$$

- (c) *The momentum polytope of $(\mathbb{P}(V), \mu_{\mathbb{P}(V)})$ is the triangle*

$$\text{conv}(0, \ell(\varepsilon_1 + \varepsilon_2), k(\varepsilon_1 + \varepsilon_2) + \varepsilon_1)$$

in case (2) of proposition 4.2.2.

- (d) *If $s \in \mathbb{R}, t \in \mathbb{R}_{>0}$, then*

$$\mu_{\mathbb{P}(V)}^{s,t} := t\mu_{\mathbb{P}(V)} + s(\varepsilon_1 + \varepsilon_2)$$

is a momentum map for the symplectic form $t\omega_{\mathbb{P}(V)}$ on $\mathbb{P}(V)$ and the momentum polytope of the multiplicity free $U(2)$ -manifold $(\mathbb{P}(V), \mu_{\mathbb{P}(V)}^{s,t})$ is the triangle

$$s(\varepsilon_1 + \varepsilon_2) + t \cdot \text{conv}(0, \ell(\varepsilon_1 + \varepsilon_2), k(\varepsilon_1 + \varepsilon_2) + \varepsilon_1)$$

of case (2) in proposition 4.2.2

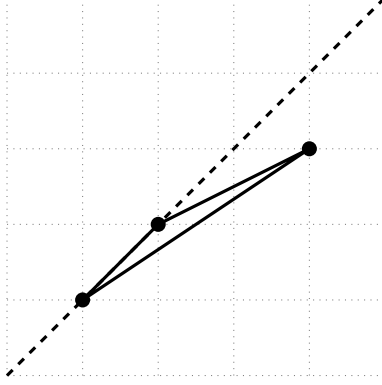

Figure 4.3: The triangle in part (d) of proposition 4.2.5 for $k = 2$, $\ell = 1$.

Proof. We begin with (a). It follows from example 1.3.2 that $(\mathbb{P}(V), \mu_{\mathbb{P}(V)})$ is a Hamiltonian $U(2)$ -manifold. A computation shows that the only element of $U(2)$ that fixes

$$[(e_1 \otimes 1) \oplus 1 \oplus 1] \in \mathbb{P}(V)$$

is the identity, which implies that the principal isotropy group of the $U(2)$ -action on $\mathbb{P}(V)$ is trivial. Since $\mathbb{P}(V)$ is compact and connected, it follows from eq. (1.3.13) that $(\mathbb{P}(V), \mu_{\mathbb{P}(V)})$ is multiplicity free.

To show (b) we first observe that all the T -weight spaces in V have dimension 1. This implies that the T -fixpoints in $\mathbb{P}(V)$ are exactly the lines spanned by T -eigenvectors in V , which shows the first assertion in (b). It follows that $\mu(x_i) \in \mathfrak{t}^* \cong (\mathfrak{t}^*)^T$ for every $i \in \{1, 2, 3, 4\}$. We now use example 1.3.2 to compute $\mu_{\mathbb{P}(V)}(x_1)$. Let $\xi \in \mathfrak{t}$. Since $v := e_1 \otimes 1 \oplus 0 \oplus 0 \in V$ has T -weight $\gamma := \varepsilon_1 - (k+1)(\varepsilon_1 + \varepsilon_2)$ we have $\xi \cdot (v) = 2\pi\sqrt{-1}\gamma(\xi)v$ which implies that $\mu_{\mathbb{P}(V)}(x_1)(\xi) = -\gamma(\xi)$, that is, $\mu_{\mathbb{P}(V)}(x) = -\gamma$, as claimed. The computations of $\mu_{\mathbb{P}(V)}(x_2)$, $\mu_{\mathbb{P}(V)}(x_3)$ and $\mu_{\mathbb{P}(V)}(x_4)$ are analogous.

We turn to (c). Since

$$\mu_{\mathbb{P}(V)}(x_2) = k(\varepsilon_1 + \varepsilon_2) + \varepsilon_1$$

is the only weight in (4.2.1) that belongs to the interior of \mathfrak{t}_+ , it is the only vertex of $\mathcal{P}(M)$ in the interior of \mathfrak{t}_+ , thanks to theorem 1.3.3(a).

In order to apply part (b) of theorem 1.3.3, we next show that the T -weights in the symplectic slice N_{x_2} of $\mathbb{P}(V)$ at x_2 are

$$\Pi_{x_2} = \{k(\varepsilon_1 + \varepsilon_2) + \varepsilon_1, (k - \ell)(\varepsilon_1 + \varepsilon_2) + \varepsilon_1\}.$$

Indeed, as $\mathbb{P}(V)$ comes with an invariant complex structure which is compatible with its Fubini-Study symplectic form by construction, we have the following isomorphisms of T -modules

$$\begin{aligned} N_{x_2} &\cong T_{x_2}\mathbb{P}(V)/T_{x_2}(K \cdot x_2) = T_{x_2}\mathbb{P}(V)/T_{x_2}\mathbb{P}(\mathbb{C}^2 \otimes \mathbb{C}_{\det^{-(k+1)}} \oplus 0 \oplus 0) \\ &\cong \mathbb{C}_{(k-\ell)(\varepsilon_1+\varepsilon_2)+\varepsilon_1} \oplus \mathbb{C}_{k(\varepsilon_1+\varepsilon_2)+\varepsilon_1}. \end{aligned}$$

Since the extremal rays

$$\mu_{\mathbb{P}(V)}(x_2) - \mathbb{R}_{\geq 0}(k(\varepsilon_1 + \varepsilon_2) + \varepsilon_1) \quad \text{and} \quad \mu_{\mathbb{P}(V)}(x_2) - \mathbb{R}_{\geq 0}((k - \ell)(\varepsilon_1 + \varepsilon_2) + \varepsilon_1)$$

of the cone $\mu_{\mathbb{P}(V)}(x_2) - \text{cone } \Pi_{x_2}$ intersect the wall of the Weyl chamber \mathfrak{t}_+ in the points 0 and $\ell(\varepsilon_1 + \varepsilon_2)$ it follows from part (b) of theorem 1.3.3 that

$$\mathcal{P}(\mathbb{P}(V)) = \text{conv}(0, \ell(\varepsilon_1 + \varepsilon_2), k(\varepsilon_1 + \varepsilon_2) + \varepsilon_1)$$

as claimed.

Part (d) follows from part (c) and lemma 4.2.4. \square

We now describe the multiplicity free $U(2)$ -manifold associated to the momentum polytope (3) of proposition 4.2.2. Recall from example 1.3.1 that $\alpha = \varepsilon_1 - \varepsilon_2$ is the simple root of $U(2)$ and $GL(2)$.

Proposition 4.2.6. *Let $j \in \mathbb{N}$ and set*

$$M = GL(2) \times_{B^-} \mathbb{P}(\mathbb{C}^2 \oplus \mathbb{C}_{-j\alpha})$$

where the group B^- of lower triangular matrices in $GL(2)$ acts on $\mathbb{P}(\mathbb{C}^2 \oplus \mathbb{C}_{-j\alpha})$ through the standard linear action of $GL(2)$ on \mathbb{C}^2 and with weight $-j\alpha$ on the 1-dimensional space $\mathbb{C}_{-j\alpha}$.

(a) The map

$$U(2) \times_T \mathbb{P}(\mathbb{C}^2 \oplus \mathbb{C}_{-j(\varepsilon_1 - \varepsilon_2)}) \rightarrow M, [g, [y]] \mapsto [g, [y]]$$

is a $U(2)$ -equivariant diffeomorphism.

(b) Let V be the irreducible $GL(2)$ -representation with highest weight $j\alpha$ and let $\mathbf{v} \in V$ be a lowest weight vector in V . Then

$$\iota_M : M \rightarrow Y := GL(2) \times_{B^-} \mathbb{P}(\mathbb{C}^2 \oplus V), [g, [u \oplus z]] \mapsto [g, [u \oplus z\mathbf{v}]]$$

is a $GL(2)$ -equivariant closed embedding and

$$\iota_Y : Y \rightarrow \mathbb{P}(\mathbb{C}^2) \times \mathbb{P}(\mathbb{C}^2 \oplus V), [g, [u \oplus v]] \mapsto ([ge_2], [gu \oplus gv])$$

is a $GL(2)$ -equivariant isomorphism of varieties.

(c) Let ω_1 be the Fubini-Study symplectic form on $\mathbb{P}(\mathbb{C}^2)$ and

$$\mu_1 : \mathbb{P}(\mathbb{C}^2) \rightarrow \mathfrak{u}(2)^*$$

the associated momentum map as in example 1.3.2, ω_2 the Fubini-Study symplectic form on $\mathbb{P}(\mathbb{C}^2 \oplus V)$ and $\mu_2 : \mathbb{P}(\mathbb{C}^2 \oplus V) \rightarrow \mathfrak{u}(2)^*$ the associated momentum map. If ω_M is the pullback along $\iota_Y \circ \iota_M$ of the symplectic form $\omega_1 + \omega_2$ on $\mathbb{P}(\mathbb{C}^2) \times \mathbb{P}(\mathbb{C}^2 \oplus V)$ then ω_M is a symplectic form on M with momentum map

$$\mu_M = (\mu_1 + \mu_2) \circ \iota_Y \circ \iota_M$$

and (M, μ_M) is a multiplicity free $U(2)$ -manifold with trivial principal isotropy group.

(d) Set $n := \begin{pmatrix} 0 & 1 \\ 1 & 0 \end{pmatrix} \in \mathrm{U}(2)$. The T -fixpoints in M are

$$\begin{aligned} x_1 &:= [e, [1 : 0 : 0]], & x_2 &:= [n, [1 : 0 : 0]], & x_3 &:= [e, [0 : 1 : 0]], \\ x_4 &:= [n, [0 : 1 : 0]], & x_5 &:= [e, [0 : 0 : 1]], & x_6 &:= [n, [0 : 0 : 1]] \end{aligned}$$

and their images under μ_M are (in the same order)

$$-\varepsilon_1 - \varepsilon_2, \quad -\varepsilon_1 - \varepsilon_2, \quad -2\varepsilon_2, \quad -2\varepsilon_1, \quad j\alpha - \varepsilon_2, \quad -j\alpha - \varepsilon_1. \quad (4.2.2)$$

(e) The momentum polytope of (M, μ_M) is the triangle $(-\varepsilon_1 - \varepsilon_2) + \mathrm{conv}(0, \alpha, j\alpha + \varepsilon_1)$ in case (3) of proposition 4.2.2

(f) If $s \in \mathbb{R}, t \in \mathbb{R}_{>0}$, then

$$\mu_M^{s,t} := t\mu_M + (s+t)(\varepsilon_1 + \varepsilon_2)$$

is a momentum map for the symplectic form $t\omega_M$ on M . The momentum polytope of the multiplicity free $\mathrm{U}(2)$ -manifold $(M, \mu_M^{s,t})$ is the triangle

$$s(\varepsilon_1 + \varepsilon_2) + t \cdot \mathrm{conv}(0, \alpha, j\alpha + \varepsilon_1)$$

of case (3) in proposition 4.2.2

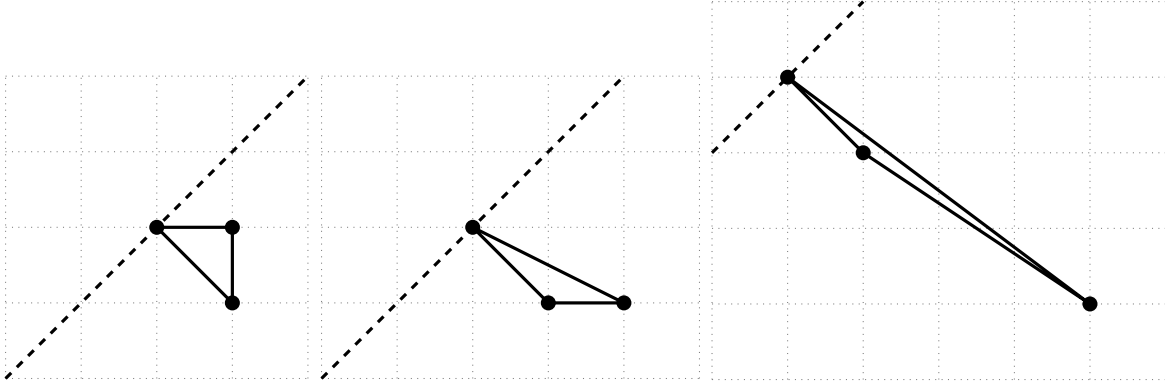

Figure 4.4: The triangle in part (e) of proposition 4.2.6 for $j = 0$, $j = 1$ and $j = 3$.

Proof. Part (a) is just an application of proposition 1.4.4.

We proceed to assertion (b). The assertion about ι_M follows from the fact that $\mathbb{C}_{-j\alpha} \rightarrow V : z \mapsto zv$ is a B^- -equivariant injective linear map. The claim about ι_Y is a standard fact; see, e.g., [Tim11, Lemma 2.3].

The assertion in (c) that (M, ω_M, μ_M) is a Hamiltonian $\mathrm{U}(2)$ -manifold follows from standard and well-known facts about Hamiltonian actions. Furthermore, a straightforward computation shows that the isotropy group $\mathrm{U}(2)_x$ of (for example) $x = [e, [1 : 1 : 1]] \in M$ is trivial, which implies that the principal isotropy group is trivial as well. It now follows from

eq. (1.3.13) and from the fact that M is compact and connected, that M is a multiplicity free.

To prove (d) we will use example 1.3.2. A straightforward calculation shows that the listed points are the six T -fixpoints in M . It follows that their images under μ_M lie in $\mathfrak{t}^* \cong (\mathfrak{t}^*)^T$. Let $\xi \in \mathfrak{t}$. We begin by computing $\mu_M(x_1)(\xi)$. First off,

$$\iota_Y \circ \iota_M(x_1) = ([e_2], [e_1 \oplus 0]).$$

Since e_2 has weight ε_2 and e_1 has weight ε_1 , we have $\xi \cdot e_2 = 2\pi\sqrt{-1}\varepsilon_2(\xi)e_2$ and $\xi \cdot (e_1 \oplus 0) = 2\pi\sqrt{-1}\varepsilon_1(\xi)(e_1 \oplus 0)$ which implies that

$$\mu_1([e_2])(\xi) = -\varepsilon_2(\xi) \text{ and } \mu_2([e_1 \oplus 0])(\xi) = -\varepsilon_1(\xi).$$

The claimed equality $\mu_M(x_1) = -\varepsilon_1 - \varepsilon_2$ follows.

Similar elementary computations yield the images of x_2 through x_6 under μ_M , using

$$\begin{aligned} \iota_Y \circ \iota_M(x_2) &= ([e_1], [e_2 \oplus 0]), \quad \iota_Y \circ \iota_M(x_3) = ([e_2], [e_2 \oplus 0]), \quad \iota_Y \circ \iota_M(x_4) = ([e_1], [e_1 \oplus 0]), \\ \iota_Y \circ \iota_M(x_5) &= ([e_2], [0 \oplus \mathfrak{v}]), \quad \iota_Y \circ \iota_M(x_6) = ([e_1], [0 \oplus n\mathfrak{v}]) \end{aligned}$$

and

$$\xi \cdot \mathfrak{v} = 2\pi\sqrt{-1}(-j\alpha)(\xi)\mathfrak{v}, \quad \xi \cdot n\mathfrak{v} = 2\pi\sqrt{-1}(j\alpha)(\xi)n\mathfrak{v},$$

which hold because \mathfrak{v} has weight $-j\alpha$ and $n\mathfrak{v}$ has weight $j\alpha$.

We turn to (e). Since

$$\mathfrak{u} := \mu_M(x_3) = -2\varepsilon_2 \text{ and } \mathfrak{w} := \mu_M(x_5) = j\alpha - \varepsilon_2$$

are the only weights in (4.2.2) that belong to the interior of \mathfrak{t}_+ , they are the only possible vertices of $\mathcal{P}(M)$ in the interior of \mathfrak{t}_+ , thanks to theorem 1.3.3(a). In order to apply part (b) of theorem 1.3.3, we next show that the T -weights in the symplectic slice N_{x_3} of M at x_3 are

$$\Pi_{x_3} = \{\alpha, -j\alpha - \varepsilon_2\}$$

whereas those in the symplectic slice N_{x_5} at x_5 are

$$\Pi_{x_5} = \{j\alpha + \varepsilon_1, j\alpha + \varepsilon_2\}.$$

Indeed, as M comes with an invariant complex structure which is compatible with ω_M by construction, we have the the following isomorphisms of T -modules

$$\begin{aligned} N_{x_3} &\cong T_{x_3}M/T_{x_3}(K \cdot x_3) \cong T_{[0:1:0]}\mathbb{P}(\mathbb{C}^2 \oplus \mathbb{C}_{-j\alpha}) \cong \mathbb{C}_{\varepsilon_1 - \varepsilon_2} \oplus \mathbb{C}_{-j\alpha - \varepsilon_2} \\ N_{x_5} &\cong T_{[0:0:1]}\mathbb{P}(\mathbb{C}^2 \oplus \mathbb{C}_{-j\alpha}) \cong \mathbb{C}_{\varepsilon_1 + j\alpha} \oplus \mathbb{C}_{\varepsilon_2 + j\alpha} \end{aligned}$$

Since the two weights in Π_{x_3} are linearly independent, theorem 1.3.3(b) implies that x_3 is a vertex of $\mathcal{P}(M)$, and the same holds for x_5 . As

$$\mathfrak{w} - (j\alpha + \varepsilon_2) = \mathfrak{u} \quad \text{and} \quad \mathfrak{u} - \alpha = \mathfrak{w} - (j\alpha + \varepsilon_1) = -\varepsilon_1 - \varepsilon_2$$

it also follows from part (b) of theorem 1.3.3 that $-\varepsilon_1 - \varepsilon_2$ is the only remaining vertex of $\mathcal{P}(M)$ and we have proven that

$$\mathcal{P}(M) = \text{conv}(-\varepsilon_1 - \varepsilon_2, \mathbf{u}, \mathbf{w}),$$

as required.

Finally, assertion (f) follows from lemma 4.2.4. \square

With proofs similar to that of proposition 4.2.6, one establishes the following descriptions of the $U(2)$ -manifolds associated to the triangles (4) and (1) of proposition 4.2.2.

Proposition 4.2.7. *Let $j \in \mathbb{N}$ and set*

$$M = \text{GL}(2) \times_{B^-} \mathbb{P}((\mathbb{C}^2)^* \oplus \mathbb{C}_{-j\alpha})$$

where the group B^- of lower triangular matrices in $\text{GL}(2)$ acts on $\mathbb{P}((\mathbb{C}^2)^* \oplus \mathbb{C}_{-j\alpha})$ through the linear action of $\text{GL}(2)$ on $(\mathbb{C}^2)^*$ dual to the standard action on \mathbb{C}^2 and with weight $-j\alpha$ on the 1-dimensional space $\mathbb{C}_{-j\alpha}$.

(a) *The map*

$$U(2) \times_T \mathbb{P}((\mathbb{C}^2)^* \oplus \mathbb{C}_{-j(\varepsilon_1 - \varepsilon_2)}) \rightarrow M, [g, [y]] \mapsto [g, [y]]$$

is a $U(2)$ -equivariant diffeomorphism.

(b) *Let V be the irreducible $\text{GL}(2)$ -representation with highest weight $j\alpha$ and let $\mathbf{v} \in V$ be a lowest weight vector in V . Then*

$$j_M : M \rightarrow \mathbb{P}(\mathbb{C}^2) \times \mathbb{P}((\mathbb{C}^2)^* \oplus V), [g, [u \oplus z]] \mapsto ([ge_2], [gu \oplus gz\mathbf{v}])$$

is a $\text{GL}(2)$ -equivariant closed embedding.

(c) *Let ω_1 be the Fubini-Study symplectic form on $\mathbb{P}(\mathbb{C}^2)$ and*

$$\mu_1 : \mathbb{P}(\mathbb{C}^2) \rightarrow \mathfrak{u}(2)^*$$

the associated momentum map as in example 1.3.2, ω_2 the Fubini-Study symplectic form on $\mathbb{P}((\mathbb{C}^2)^ \oplus V)$ and $\mu_2 : \mathbb{P}(\mathbb{C}^2 \oplus V) \rightarrow \mathfrak{u}(2)^*$ the associated momentum map. If ω_M is the pullback along j_M of the symplectic form $\omega_1 + \omega_2$ on $\mathbb{P}(\mathbb{C}^2) \times \mathbb{P}((\mathbb{C}^2)^* \oplus V)$ then ω_M is a symplectic form on M with momentum map*

$$\mu_M = (\mu_1 + \mu_2) \circ j_M$$

and (M, μ_M) is a multiplicity free $U(2)$ -manifold with trivial principal isotropy group.

(d) *The momentum polytope of (M, μ_M) is the triangle $\text{conv}(0, \alpha, j\alpha - \varepsilon_2)$ in case (4) of proposition 4.2.2*

(e) If $s \in \mathbb{R}, t \in \mathbb{R}_{>0}$, then

$$\mu_M^{s,t} := t\mu_M + s(\varepsilon_1 + \varepsilon_2)$$

is a momentum map for the symplectic form $t\omega_M$ on M . The momentum polytope of the multiplicity free $U(2)$ -manifold $(M, \mu_M^{s,t})$ is the triangle

$$s(\varepsilon_1 + \varepsilon_2) + t \cdot \text{conv}(0, \alpha, j\alpha - \varepsilon_2)$$

in case (4) of proposition 4.2.2.

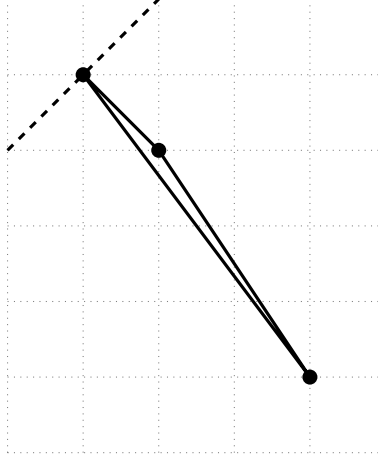

Figure 4.5: The triangle in part (d) of proposition 4.2.7 for $j = 3$.

Proposition 4.2.8. Let $a_1, b_1, a_2, b_2 \in \mathbb{Z}$ with $\det \begin{pmatrix} a_1 & a_2 \\ b_1 & b_2 \end{pmatrix} = 1$ and $a_i + b_i \geq 0$ for each $i \in \{1, 2\}$. Set $\delta_1 = a_1(-\varepsilon_2) + b_1\varepsilon_1$, $\delta_2 = a_2(-\varepsilon_2) + b_2\varepsilon_1$ and

$$M = \text{GL}(2) \times_{B^-} \mathbb{P}(\mathbb{C} \oplus \mathbb{C}_{-\delta_1} \oplus \mathbb{C}_{-\delta_2})$$

where the group B^- of lower triangular matrices in $\text{GL}(2)$ acts on $\mathbb{P}(\mathbb{C} \oplus \mathbb{C}_{-\delta_1} \oplus \mathbb{C}_{-\delta_2})$ through its linear action with weight $0, -\delta_1$ and $-\delta_2$ on the 1-dimensional spaces $\mathbb{C}, \mathbb{C}_{-\delta_1}$ and $\mathbb{C}_{-\delta_2}$, respectively.

(a) The map

$$U(2) \times_T \mathbb{P}(\mathbb{C} \oplus \mathbb{C}_{-\delta_1} \oplus \mathbb{C}_{-\delta_2}) \rightarrow M, [g, [y]] \mapsto [g, [y]]$$

is a $U(2)$ -equivariant diffeomorphism.

(b) For $i \in \{1, 2\}$, let V_i be the irreducible $\text{GL}(2)$ -representation with lowest weight $-\delta_i$ and let \mathbf{v}_i be a lowest weight vector in V_i . Then

$$j_M : M \rightarrow \mathbb{P}(\mathbb{C}^2) \times \mathbb{P}(\mathbb{C} \oplus V_1 \oplus V_2), [g, [z_0 \oplus z_1 \oplus z_2]] \mapsto ([ge_2], [z_0 \oplus gz_1\mathbf{v}_1 \oplus gz_2\mathbf{v}_2])$$

is a $\text{GL}(2)$ -equivariant closed embedding.

(c) Let $c \in \mathbb{R}_{>0}$. We write ω_1 for the Fubini-Study symplectic form on $\mathbb{P}(\mathbb{C}^2)$ and

$$\mu_1 : \mathbb{P}(\mathbb{C}^2) \rightarrow \mathfrak{u}(2)^*$$

for the associated momentum map as in example 1.3.2, ω_2 for the Fubini-Study symplectic form on $\mathbb{P}(\mathbb{C} \oplus V_1 \oplus V_2)$ and $\mu_2 : \mathbb{P}(\mathbb{C} \oplus V_1 \oplus V_2) \rightarrow \mathfrak{u}(2)^*$ for the associated momentum map. If ω_M^c is the pullback along j_M of the symplectic form $c\omega_1 + \omega_2$ on $\mathbb{P}(\mathbb{C}^2) \times \mathbb{P}(\mathbb{C} \oplus V_1 \oplus V_2)$ then ω_M^c is a symplectic form on M with momentum map

$$\mu_M^c = (c\mu_1 + \mu_2) \circ j_M$$

and (M, μ_M^c) is a multiplicity free $U(2)$ -manifold with trivial principal isotropy group.

(d) The momentum polytope of (M, μ_M^c) is the triangle $c(-\varepsilon_2) + \text{conv}(0, \delta_1, \delta_2)$ in case (1) of proposition 4.2.2

(e) If $s \in \mathbb{R}, r, t \in \mathbb{R}_{>0}$, then

$$\mu_M^{r,s,t} := t\mu_M^{r/t} + s(\varepsilon_1 + \varepsilon_2)$$

is a momentum map for the symplectic form $t\omega_M^{r/t}$ on M . The momentum polytope of the multiplicity free $U(2)$ -manifold $(M, \mu_M^{s,t})$ is the triangle

$$r(-\varepsilon_2) + s(\varepsilon_1 + \varepsilon_2) + t \cdot \text{conv}(0, \delta_1, \delta_2)$$

of case (1) of proposition 4.2.2.

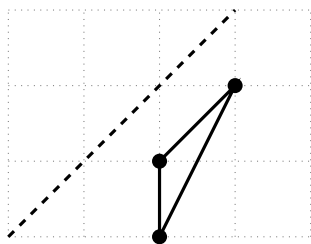

Figure 4.6: The triangle in part (d) of proposition 4.2.8 for $c = 1$, $\begin{pmatrix} a_1 & a_2 \\ b_1 & b_2 \end{pmatrix} = \begin{pmatrix} 1 & -1 \\ 0 & 1 \end{pmatrix}$.

Finally, we describe the multiplicity free $U(2)$ -manifold associated to the momentum polytope (5) of proposition 4.2.2.

Proposition 4.2.9. *Let*

$$M = \text{SO}(5)/[\text{SO}(2) \times \text{SO}(3)]$$

be the Grassmannian of oriented 2-planes in \mathbb{R}^5 . We give M the structure of a Hamiltonian $\text{SO}(5)$ -manifold by viewing it as the coadjoint orbit through the short roots of $\text{SO}(5)$, with respect to the maximal torus $S = \left\{ \begin{pmatrix} A & 0 & 0 \\ 0 & B & 0 \\ 0 & 0 & 1 \end{pmatrix} : A, B \in \text{SO}(2) \right\}$. We define an embedding

$\iota : \mathrm{U}(2) \hookrightarrow \mathrm{SO}(5)$ by embedding $\mathrm{SO}(4)$ into $\mathrm{SO}(5)$ as the upper left block and identifying $\mathrm{U}(2)$ with the centralizer of $\left\{ \begin{pmatrix} A & 0 \\ 0 & A \end{pmatrix} : A \in \mathrm{SO}(2) \right\}$ in $\mathrm{SO}(4)$ in such a way that the restriction of ι to T is an isomorphism from T onto S that identifies the short roots of $\mathrm{SO}(5)$ with the four weights $-\varepsilon_1, -\varepsilon_2, \varepsilon_1, \varepsilon_2 \in \Lambda$ of $\mathrm{U}(2)$.

Let $\mu_M : M \rightarrow \mathfrak{u}(2)^*$ be the momentum map and ω_M be the symplectic form of the restricted Hamiltonian $\mathrm{U}(2)$ -action on M induced by the inclusion $\iota : \mathrm{U}(2) \hookrightarrow \mathrm{SO}(5)$.

- (a) (M, ω_M, μ_M) is a multiplicity free $\mathrm{U}(2)$ -manifold with trivial principal isotropy group whose momentum polytope is the triangle $\mathrm{conv}(0, \varepsilon_1, -\varepsilon_2)$, in case (5) of proposition 4.2.2.
- (b) If $s \in \mathbb{R}$ and $t \in \mathbb{R}_{\geq 0}$, then $(M, t\omega_M, t\mu_M + s(\varepsilon_1 + \varepsilon_2))$ is a multiplicity free $\mathrm{U}(2)$ -manifold with trivial principal isotropy group whose momentum polytope is the triangle

$$s(\varepsilon_1 + \varepsilon_2) + t \cdot \mathrm{conv}(0, \varepsilon_1, -\varepsilon_2),$$

of case (5) of proposition 4.2.2.

Proof. Since (b) follows from (a) and lemma 4.2.4, we only need to prove part (a). Let $r : \mathfrak{u}(2)^* \rightarrow \mathfrak{t}^*$ be the restriction map. Then $\mu_T = r \circ \mu_M$ is the momentum map of the restricted T -action on M . The momentum polytope $\mathcal{P}_T(M) = \mu_T(M)$ of this restricted T -action was computed in [CK13, Example 4.2] to be the following square:

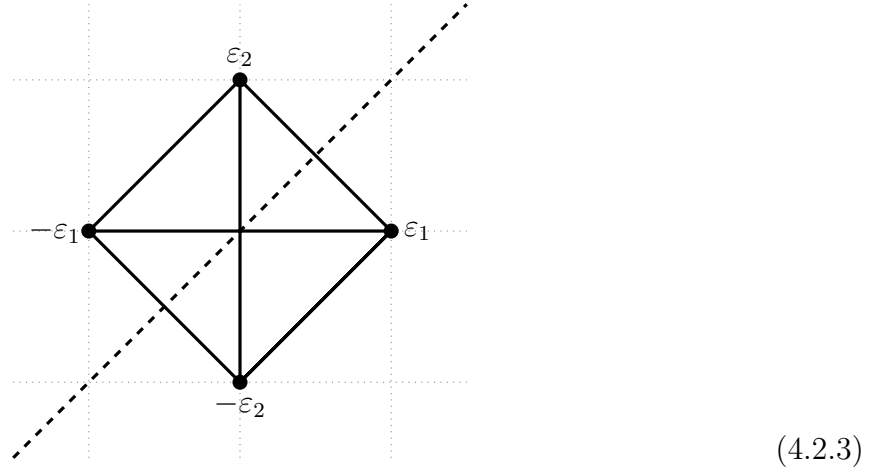

In this picture, the lines (also the ones in the interior of the momentum image) are the images under μ_T of the points of M with nontrivial T -isotropy, and the dots are the images of the four T -fixed points. Our goal is to show that the $\mathrm{U}(2)$ -momentum polytope $\mathcal{P}(M)$ of M is

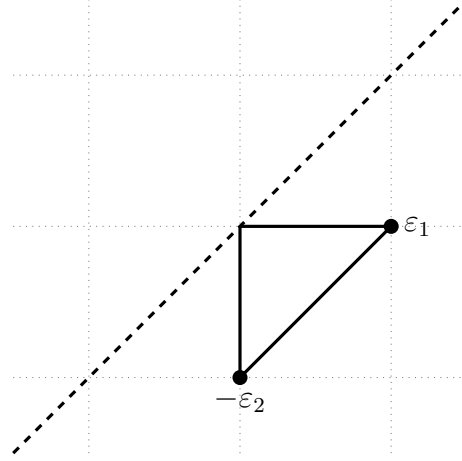

and that M is a multiplicity free $U(2)$ -Hamiltonian manifold with trivial principal isotropy group.

By theorem 1.3.3(a), any vertex of $\mathcal{P}(M)$ that lies in the interior of \mathfrak{t}_+ is the image under μ_M of a T -fixed point. Together with proposition 1.3.5 it follows that ε_1 and $-\varepsilon_2$ are the only two vertices of $\mathcal{P}(M)$ in \mathfrak{t}_+ . In order to show that $\mathcal{P}(M)$ is the asserted triangle, we now only need to prove that the two points where the boundary of the T -momentum image $\mathcal{P}_T(M)$ intersects the Weyl wall do not lie in $\mathcal{P}(M)$. Let q be the T -fixed point on M with $\mu_M(q) = \varepsilon_1$. Then the orbit $U(2) \cdot q \cong U(2)/T \cong S^2$ is, via the T -momentum map μ_T , mapped onto the line segment between ε_1 and ε_2 . This implies that the weights of the T -representation on the symplectic slice N_q in q are given by the directions of the other two rays emerging from ε_1 in (4.2.3). Then theorem 1.3.3(b) implies that $\mathcal{P}(M)$ has the desired form locally around ε_1 . Together with similar considerations near $-\varepsilon_2$, this forces $\mathcal{P}(M)$ to be globally as claimed.

Next we show the claim that M contains points with trivial isotropy. A neighborhood of q is $U(2)$ -equivariantly diffeomorphic to $U(2) \times_T N_q$ (see remark 1.3.4(b)). Note that T acts on the symplectic slice N_q with two weights which form a basis of the weight lattice Λ , because they are a long and a short root of $SO(5)$. The claim follows. Since M has dimension 6, eq. (1.3.13) now yields that M is a multiplicity free $U(2)$ -manifold. \square

4.3 Diffeomorphism types

In this final section we discuss the nonequivariant diffeomorphism types of the manifolds in table 4.2. We start off with a brief review of some standard facts in the theory of (real or complex) vector bundles $V \rightarrow E \xrightarrow{\pi} S^k$ with structure group $G \subset GL(V)$ over spheres (for details, see [Hat17, Section 1.2]). Denote by N and S the north and south pole of the k -sphere S^k ($k \geq 2$), respectively. Then both $U^- := S^k \setminus \{N\}$ and $U^+ = S^k \setminus \{S\}$ are homeomorphic to the open k -disk U^k and therefore contractible, so there are trivializations

$$\phi^-: \pi^{-1}(U^-) \rightarrow U^- \times V, \quad \phi^+: \pi^{-1}(U^+) \rightarrow U^+ \times V.$$

Now, as $U^- \cap U^+ \cong S^{k-1} \times (-1, 1)$, we obtain a map

$$\phi^+ \circ \phi^- : S^{k-1} \times (-1, 1) \times V \rightarrow S^{k-1} \times (-1, 1) \times V,$$

which is of the form $(x, t, v) \mapsto (x, t, \gamma(x, t)(v))$, for a map $\gamma : S^{k-1} \times (-1, 1) \rightarrow G$. In particular, the map

$$\gamma_E : S^{k-1} \rightarrow G, \gamma_E(x) = \gamma(x, 0),$$

defines an element $[\gamma_E]$ in the set $[S^{k-1}, G]$ of free homotopy classes of maps from S^{k-1} to G .

Conversely, given an element $[\gamma] \in [S^{k-1}, G]$ represented by $\gamma : S^{k-1} \rightarrow G$, we can define a bundle $V \rightarrow E_\gamma \xrightarrow{\pi} S^k$ by gluing two copies of $D^k \times V$, where D^k is the closed k -disk, together via γ . More precisely, writing $D^- \times V$ and $D^+ \times V$ for the two copies of $D^k \times V$, we define

$$E_\gamma := (D^- \times V) \cup_{\phi_\gamma} (D^+ \times V),$$

where $\phi_\gamma : \partial D^- \times V \rightarrow \partial D^+ \times V$ is given by $\phi_\gamma(x, v) = (x, \gamma(x)(v))$. This is called the *clutching construction* and γ the *clutching function*. It turns out that the isomorphism class of this bundle only depends on the free homotopy class of γ and that this construction inverts the assignment $[E] \mapsto [\gamma_E]$ described above. In summary, we have the following

Theorem 4.3.1. *The map from $[S^{k-1}, G]$ to the set of isomorphism classes of vector bundles $V \rightarrow E \rightarrow S^k$ with structure group $G \subset \text{GL}(V)$, which is given by mapping $[\gamma] \in [S^{k-1}, G]$ to the isomorphism class of the bundle E_γ , is a bijection. Its inverse is given by the assignment $[E] \mapsto [\gamma_E]$.*

Recall that the set $\text{Vect}^1(S^2)$ of isomorphism classes of complex line bundles over S^2 is an abelian group with respect to the tensor product operation. Theorem 4.3.1 gives us the bijection $\text{Vect}^1(S^2) \rightarrow [S^1, \text{GL}(1, \mathbb{C})], [E] \mapsto [\gamma_E]$. Since $S^1 = \text{U}(1) \subset \text{GL}(1, \mathbb{C})$ is a deformation retract of $\text{GL}(1, \mathbb{C}) = \mathbb{C}^\times$ we can identify $[S^1, \text{GL}(1, \mathbb{C})]$ with $[S^1, S^1] = \pi_1(S^1)$. Also, by definition, the tensor product of two line bundles E_1 and E_2 has the clutching function $\gamma_{E_1} \cdot \gamma_{E_2}$ (multiplying in $S^1 = \text{U}(1)$), which makes the assignment

$$\text{Vect}^1(S^2) \rightarrow \pi_1(S^1) : [E] \mapsto [\gamma_E]$$

a group homomorphism and, by theorem 4.3.1, a group isomorphism.

We now fix group isomorphisms $\phi_1 : \text{Vect}^1(S^2) \rightarrow \mathbb{Z}$ and $\phi_2 : \pi_1(S^1) \rightarrow \mathbb{Z}$. Such isomorphisms are unique up to sign, but it will turn out that the choice of sign will not be important in what follows. By abuse of notation, we will write $\phi_1(E)$ for $\phi_1([E])$ and $\phi_2(\gamma)$ for $\phi_2([\gamma])$. Since $H^2(S^2, \mathbb{Z}) \cong \mathbb{Z}$, $\phi_1(E)$ can be understood as the Chern class of the complex line bundle E up to sign, see e.g. [Hat17, Proposition 3.10].

Lemma 4.3.2. *Let S^1 act on S^2 by standard rotation and on two copies of \mathbb{C} via weights $k_1 \in \mathbb{Z}$ and $k_2 \in \mathbb{Z}$, respectively. Consider the corresponding S^1 -equivariant line bundle $\mathbb{C} \rightarrow E \rightarrow S^2$ with weight k_1 on the fibre at the south pole S and k_2 on the fibre at the north pole N . Then $\phi_1(E) = \pm(k_1 - k_2)$, depending on the chosen ϕ_1 .*

Proof. We only have to determine $\phi_2(\gamma)$ up to sign, where $\gamma : S^1 \rightarrow S^1$ is the clutching function of the line bundle E . Trivializations of E around S and N look like $D^2 \times \mathbb{C}$ with S^1 -actions

$$s \cdot (z_1, z_2) = (sz_1, s^{k_1}z_2) \quad \text{and} \quad s \cdot (z_1, z_2) = (sz_1, s^{k_2}z_2),$$

respectively. The isomorphism between the boundaries of these two trivializations induced by the clutching function γ has to preserve this S^1 -action, which gives the condition (now $z_1 \in \partial D^2 = S^1$)

$$(sz_1, \gamma(sz_1)s^{k_2}z_2) = (sz_1, s^{k_1}\gamma(z_1)z_2).$$

This immediately implies that $\phi_2(\gamma)$ is $\pm(k_1 - k_2)$, the sign depending on the choice of ϕ_2 . \square

Theorem 4.3.3. *There are precisely four diffeomorphism types occurring in table 4.2:*

- (a) *the manifolds in case (2) are diffeomorphic to $\mathbb{P}(\mathbb{C}^4)$,*
- (b) *the manifold in case (5) has the diffeomorphism type of the Grassmannian of oriented 2-planes in \mathbb{R}^5 ,*
- (c) *those manifolds $U(2) \times_T \mathbb{P}(V)$ in cases (1), (3) and (4) for which the first Chern class of the vector bundle $V \rightarrow U(2) \times_T V \rightarrow U(2)/T$ is divisible by 3 are diffeomorphic to $S^2 \times \mathbb{P}(\mathbb{C}^3)$,*
- (d) *those manifolds $U(2) \times_T \mathbb{P}(V)$ in cases (1), (3) and (4) for which the first Chern class of the vector bundle $V \rightarrow U(2) \times_T V \rightarrow U(2)/T$ is not divisible by 3 are diffeomorphic to the total space of any non-trivial $\mathbb{P}(\mathbb{C}^3)$ -bundle over S^2 .*

Proof. As $\mathbb{P}(\mathbb{C}^4)$ is spin and the aforementioned Grassmannian is not, these two manifolds are not diffeomorphic. In addition, both of them are not diffeomorphic to the manifolds occurring in cases (1), (3) and (4) of table 4.2 due to the equality of Euler characteristics $\chi(M) = \chi(M^T)$ which holds for any torus action on a compact manifold M . The real task here is to distinguish between the manifolds in cases (1), (3) and (4).

Let $M = U(2) \times_T \mathbb{P}(V)$ be one of these manifolds. As the projective bundle of the vector bundle $E = U(2) \times_T V$ of rank 3 over $U(2)/T \cong S^2$, it can be described by a clutching function $\gamma : S^1 \rightarrow \text{PGL}(3, \mathbb{C})$, which comes from the clutching function $\tilde{\gamma}$ of E . Because E is the sum $L_1 \oplus L_2 \oplus L_3$ of three line bundles, we have $\tilde{\gamma} = (\gamma_1, \gamma_2, \gamma_3) : S^1 \rightarrow U(1)^3 \subset U(3)$, where γ_1, γ_2 and γ_3 are the clutching functions of L_1, L_2 and L_3 . The class of $\tilde{\gamma}$ in $\pi_1(U(3)) = \pi_1(\text{GL}(3, \mathbb{C})) = \mathbb{Z}$ is now given by

$$\phi_2(\det(\tilde{\gamma})) = \phi_2(\gamma_1) + \phi_2(\gamma_2) + \phi_2(\gamma_3).$$

It follows that the class of γ in $[S_1, \text{PGL}(3, \mathbb{C})] = \pi_1(\text{PGL}(3, \mathbb{C})) = \mathbb{Z}/3\mathbb{Z}$ is determined by the value

$$f(\gamma) := [\phi_2(\gamma_1 \cdot \gamma_2 \cdot \gamma_3)] = [\phi_2(\gamma_1) + \phi_2(\gamma_2) + \phi_2(\gamma_3)] \in \mathbb{Z}/3\mathbb{Z},$$

since the fibration $Z(\mathrm{GL}(3, \mathbb{C})) \rightarrow \mathrm{GL}(3, \mathbb{C}) \rightarrow \mathrm{PGL}(3, \mathbb{C})$ induces a short exact sequence

$$0 \rightarrow \pi_1(Z(\mathrm{GL}(3, \mathbb{C}))) \rightarrow \pi_1(\mathrm{GL}(3, \mathbb{C})) \rightarrow \pi_1(\mathrm{PGL}(3, \mathbb{C})) \rightarrow 0.$$

Note that $f(\gamma)$ is equal up to sign to $\phi_1(L_1) + \phi_1(L_2) + \phi_1(L_3)$ modulo 3, where the L_i are the line bundles from above and ϕ_1 is the fixed isomorphism $\mathrm{Vect}^1(S^2) \rightarrow \mathbb{Z}$.

We only need to check that the total spaces E_1 and E_{-1} of the $\mathbb{P}(\mathbb{C}^3)$ -bundles with $f(\gamma_+) = 1$ and $f(\gamma_-) = -1$, where $\gamma_+ : S^1 \rightarrow \mathrm{PGL}(3, \mathbb{C})$ and $\gamma_- : S^1 \rightarrow \mathrm{PGL}(3, \mathbb{C})$ are the clutching functions of E_1 and E_{-1} , are diffeomorphic, and that E_1 and $S^2 \times \mathbb{P}(\mathbb{C}^3)$ are not (note that all these statements do not depend on the isomorphisms ϕ_1 and ϕ_2 we have chosen).

Because the vector bundles of $E_{\pm 1}$ are sums of three line bundles, the first statement follows immediately from the fact that two complex line bundles over S^2 , whose first Chern classes differ only in their sign, are \mathbb{C} -antilinearly isomorphic (as a change in sign of the first Chern class corresponds to a change in sign of the complex structure on the fiber). The second statement is true as E_1 and $S^2 \times \mathbb{P}(\mathbb{C}^3)$ are not even homotopy equivalent. Indeed, by e.g. [Hus94, §17.2], the cohomology ring of E_1 is $\mathbb{Z}[x, y]/(x^2, y^3 + xy^2)$, where x represents a generator of $H^*(S^2)$ and y represents a generator of $H^*(\mathbb{P}(\mathbb{C}^3))$, whereas $H^*(S^2 \times \mathbb{P}(\mathbb{C}^3)) = \mathbb{Z}[x, y]/(x^2, y^3)$. These two cohomology rings are not isomorphic since any graded ring isomorphism

$$\mathbb{Z}[x, y]/(x^2, y^3) \rightarrow \mathbb{Z}[x, y]/(x^2, y^3 + xy^2)$$

would have to send x to $\pm x$ and therefore y to $ax \pm y$ for some $a \in \mathbb{Z}$, but $y^3 = 0$ on the left, whereas $(ax \pm y)^3 = 3axy^2 \pm y^3 \neq 0$ on the right. \square

Remark 4.3.4. In order to determine the first Chern class modulo 3 of the \mathbb{C}^3 -bundle E giving the $\mathbb{P}(\mathbb{C}^3)$ -bundle M of case (1), (3) or (4) in table 4.2, it is sufficient to look at the directions $\lambda_1 = a_1\varepsilon_1 + b_1\varepsilon_2$ and $\lambda_2 = a_2\varepsilon_1 + b_2\varepsilon_2$ in which the edges of the momentum polytope $\mathcal{P}(M)$ emerge at some vertex \mathbf{v} . Indeed, a neighborhood of the $U(2)$ -orbit $\Psi^{-1}(\mathbf{v})$ in M looks like the bundle $L' = U(2) \times_T (\mathbb{C}_{-\lambda_1} \oplus \mathbb{C}_{-\lambda_2})$. Now consider the action of $U(1) \times \{e\} \subset T \subset U(2)$ on L' and note that the weights of that circle action on the fiber over $eT \in U(2)/T$ are given by $-a_1$ and $-a_2$, whereas the weights in the fiber over the other T -fixed point in $U(2)/T$ are $-b_1$ and $-b_2$. Using lemma 4.3.2, we see that the first Chern class of L' is (up to sign) equal to $-a_1 - a_2 + b_1 + b_2$. Now observe that $\mathbb{P}(L' \oplus \underline{\mathbb{C}}) = \mathbb{P}(E) = M$, which implies that M is diffeomorphic to $S^2 \times \mathbb{P}(\mathbb{C}^3)$ if and only if $a_1 + a_2 - b_1 - b_2$ is a multiple of 3.

Bibliography

- [Ati82] M. F. Atiyah, *Convexity and commuting Hamiltonians*, Bull. London Math. Soc. **14** (1982), no. 1, 1–15. MR642416
- [A18] Anton Ayzenberg, *Torus actions of complexity 1 and their local properties*, Proc. Steklov Inst. Math. **302** (2018), no. 1, 16–32.
- [AM19] Anton Ayzenberg and Mikiya Masuda, *Orbit spaces of equivariantly formal torus actions*, arXiv:1912.11696v1 [math.AT], 2019
- [AMS22] Anton Ayzenberg, Mikiya Masuda and Grigory Solomadin, *How is a graph not like a manifold?*, arXiv:2203.10641v1 [math.AT], 2022
- [BP15] Victor M. Buchstaber and Taras E. Panov, *Toric topology.*, American Mathematical Society, Providence, RI, 2015. xiv+518 pp., 2015
- [CS74] Theodore Chang and Tor Skjelbred, *The topological Schur lemma and related results.*, Ann. Math. (2) **100** (1974), 307–321.
- [CFPVS20] Stéphanie Cupit-Foutou, Guido Pezzini, and Bart Van Steirteghem, *Momentum polytopes of projective spherical varieties and related Kähler geometry*, Selecta Math. (N.S.) **26** (2020), no. 2, 27. MR4083681
- [CK13] Yunhyung Cho and Min Kyu Kim, *Hamiltonian circle action with self-indexing moment map*, arXiv:1312.6512v1 [math.SG], 2013.
- [Del88] Thomas Delzant, *Hamiltoniens périodiques et images convexes de l'application moment*, Bull. Soc. Math. France **116** (1988), no. 3, 315–339. MR984900 (90b:58069)
- [Del90] ———, *Classification des actions hamiltoniennes complètement intégrables de rang deux*, Ann. Global Anal. Geom. **8** (1990), no. 1, 87–112. MR1075241 (92f:58078)
- [FP07] Matthias Franz and Volker Puppe, *Exact cohomology sequences with integral coefficients for torus actions.*, Transform. Groups **12** (2007), no. 1, 65–76., 2007
- [Ful93] William Fulton, *Introduction to toric varieties*, Annals of Mathematics Studies, vol. 131, Princeton University Press, Princeton, NJ, 1993, The William H. Roever Lectures in Geometry. MR1234037 (94g:14028)
- [GKZ20] Oliver Goertsches, Panagiotis Konstantis and Leopold Zoller, *Realization of GKM fibrations and new examples of Hamiltonian non-Kähler actions*, arXiv:2003.11298v1
- [GKZ22] Oliver Goertsches, Panagiotis Konstantis and Leopold Zoller, *The GKM correspondence in dimension 6*, Preprint, arXiv:2210.01856, 2022
- [GSW22] Oliver Goertsches, Bart Van Steirteghem and Nikolas Wardenski, *Multiplicity free $U(2)$ -actions and triangles*, arXiv:2208.02099v1

- [GZ19] Oliver Goertsches and Leopold Zoller, *Equivariant de Rham cohomology: theory and applications.*, São Paulo J. Math. Sci.13(2019), no.2, 539–596.
- [GKM98] Mark Goresky, Robert Kottwitz and Robert MacPherson, *Equivariant cohomology, Koszul duality, and the localization theorem*, Invent. Math. 131, 1 (1998), 25–83.
- [GHV73] Werner Greub, Stephen Halperin and Ray Vanstone, *Connections, curvature, and cohomology*. Vol. II: Lie groups, principal bundles, and characteristic classes, Pure and Applied Mathematics, vol. 47-II. Academic Press, New York-London, 1973
- [GHZ06] Victor Guillemin, Tara Holm and Catalin Zara, *A GKM description of the equivariant cohomology ring of a homogeneous space*, J. Algebraic Combin. 23, 1 (2006), 21–41.
- [GSZ12] Victor Guillemin, Silvia Sabatini, and Catalin Zara, *Cohomology of GKM fiber bundles*, J. Algebraic Combin. 35, 1 (2012), 19–59.
- [GS82] V. Guillemin and S. Sternberg, *Convexity properties of the moment mapping*, Invent. Math. **67** (1982), no. 3, 491–513. MR664117
- [GS84] Victor Guillemin and Shlomo Sternberg, *Multiplicity-free spaces*, J. Differential Geom. **19** (1984), no. 1, 31–56. MR739781 (85h:58071)
- [GS05] Victor Guillemin and Reyer Sjamaar, *Convexity properties of Hamiltonian group actions*, CRM Monograph Series, vol. 26, American Mathematical Society, Providence, RI, 2005. MR2175783
- [GS84] Victor Guillemin and Shlomo Sternberg, *Multiplicity-free spaces*, J. Differential Geom. **19** (1984), no. 1, 31–56. MR739781 (85h:58071)
- [GS90] ———, *Symplectic techniques in physics*, second ed., Cambridge University Press, Cambridge, 1990. MR1066693 (91d:58073)
- [GS05] Victor Guillemin and Reyer Sjamaar, *Convexity properties of Hamiltonian group actions*, CRM Monograph Series, vol. 26, American Mathematical Society, Providence, RI, 2005. MR2175783
- [Hat04] Allen Hatcher, *Spectral sequences*, online, <https://pi.math.cornell.edu/~hatcher/AT/ATch5.pdf>
- [Hat17] Allen Hatcher, *Vector bundles and K-theory*, online, 2017, <https://pi.math.cornell.edu/~hatcher/VBKT/VBpage.html> (version 2.2).
- [Hus94] Dale Husemoller, *Fibre bundles*, third ed., Graduate Texts in Mathematics, vol. 20, Springer-Verlag, New York, 1994. MR1249482
- [HW90] A. T. Huckleberry and T. Wurzbacher, *Multiplicity-free complex manifolds*, Math. Ann. **286** (1990), no. 1-3, 261–280. MR1032934 (91c:32027)
- [YK99] Yael Karshon, *Periodic Hamiltonian flows on four-dimensional manifolds.*, Mem. Amer. Math. Soc.141(1999), no.672, viii+71 pp.
- [Kaw91] Katsuo Kawakubo, *The theory of transformation groups*, japanese ed., The Clarendon Press, Oxford University Press, New York, 1991. MR1150492
- [Kir84] Frances Kirwan, *Convexity properties of the moment mapping. III*, Invent. Math. **77** (1984), no. 3, 547–552. MR759257 (86b:58042b)
- [Kno11] Friedrich Knop, *Automorphisms of multiplicity free Hamiltonian manifolds*, J. Amer. Math. Soc. **24** (2011), no. 2, 567–601. MR2748401 (2012a:53160)
- [Ler95] Eugene Lerman, *Symplectic cuts*, Math. Res. Lett. **2** (1995), no. 3, 247–258. MR1338784
- [LMTW98] Eugene Lerman, Eckhard Meinrenken, Sue Tolman, and Chris Woodward, *Nonabelian convexity by symplectic cuts*, Topology **37** (1998), no. 2, 245–259. MR1489203

- [Los09] Ivan V. Losev, *Proof of the Knop conjecture*, Ann. Inst. Fourier (Grenoble) **59** (2009), no. 3, 1105–1134. MR2543664
- [Mar88] Charles-Michel Marle, *Construction d'actions hamiltoniennes de groupes de Lie*, Action hamiltoniennes de groupes. Troisième théorème de Lie (Lyon, 1986), Travaux en Cours, vol. 27, Hermann, Paris, 1988, pp. 57–70. MR951170
- [MP03] Mikiya Masuda and Taras E. Panov, *On the cohomology of torus manifolds*, arXiv:math/0306100v2 [math.AT], 2003
- [MF78] A. S. Miščenko and A. T. Fomenko, *A generalized Liouville method for the integration of Hamiltonian systems*, Funkcional. Anal. i Priložen. **12** (1978), no. 2, 46–56, 96. MR0516342 (58 #24357)
- [MT12] Johan Martens and Michael Thaddeus, *On non-Abelian symplectic cutting*, Transform. Groups **17** (2012), no. 4, 1059–1084. MR3000481
- [PPVS18] Kay Paulus, Guido Pezzini, and Bart Van Steirteghem, *On Some Families of Smooth Affine Spherical Varieties of Full Rank*, Acta Math. Sin. (Engl. Ser.) **34** (2018), no. 3, 563–596. MR3763978
- [PV94] V. L. Popov and È. B. Vinberg, *Invariant theory*, Algebraic Geometry IV (A.N. Parshin and I.R. Shafarevich, eds.), Encyclopaedia of Mathematical Sciences, vol. 55, Springer, Berlin, Heidelberg, 1994, pp. 123–278.
- [PVS19] Guido Pezzini and Bart Van Steirteghem, *Combinatorial characterization of the weight monoids of smooth affine spherical varieties*, Trans. Amer. Math. Soc. **372** (2019), no. 4, 2875–2919. MR3988597
- [Ser56] Jean-Pierre Serre, *Géométrie algébrique et géométrie analytique*, Ann. Inst. Fourier (Grenoble) **6** (1955/56), 1–42. MR82175
- [Sja98] Reyer Sjamaar, *Convexity properties of the moment mapping re-examined*, Adv. Math. **138** (1998), no. 1, 46–91. MR1645052 (2000a:53148)
- [Tim11] Dmitry A. Timashev, *Homogeneous spaces and equivariant embeddings*, Encyclopaedia of Mathematical Sciences, vol. 138, Springer, Heidelberg, 2011, Invariant Theory and Algebraic Transformation Groups, 8. MR2797018 (2012e:14100)
- [Tol98] Susan Tolman, *Examples of non-Kähler Hamiltonian torus actions*, Invent. Math. **131** (1998), no. 2, 299–310. MR1608575
- [TY05] Patrice Tauvel and Rupert W. T. Yu, *Lie algebras and algebraic groups*, Springer Monographs in Mathematics, Springer-Verlag, Berlin, 2005. MR2146652 (2006c:17001)
- [Woo96] Chris Woodward, *The classification of transversal multiplicity-free group actions*, Ann. Global Anal. Geom. **14** (1996), no. 1, 3–42. MR1375064 (97a:58067)
- [Woo98a] ———, *Multiplicity-free Hamiltonian actions need not be Kähler*, Invent. Math. **131** (1998), no. 2, 311–319. MR1608579 (2000d:53130)
- [Woo98b] Chris T. Woodward, *Spherical varieties and existence of invariant Kähler structures*, Duke Math. J. **93** (1998), no. 2, 345–377. MR1625995 (99d:58072)
- [Z16] Leopold Zoller, *On the Toral Rank Conjecture in Kähler and Contact Geometry*, Master's thesis, 2016